

INSTE^C®

Focus on Excellence

2015

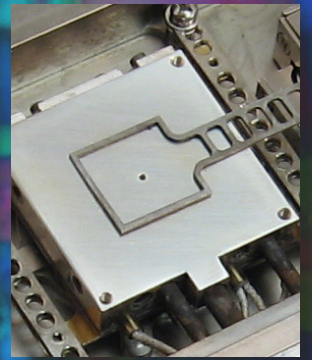

Hot and Cold Stages
Precision Temperature Controllers
Liquid Crystal Cell Holders
Microscope Ready Digital Cameras

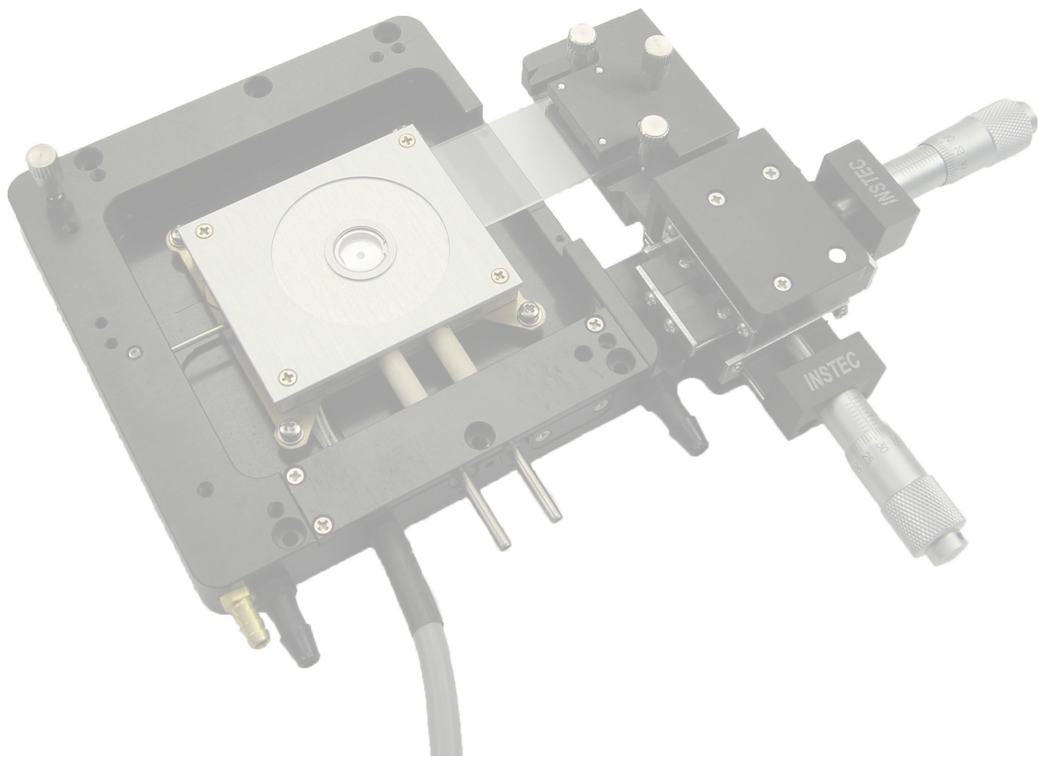



Superior design quality comes from years of experience. Instec, Inc. was founded in 1984 by a group of pioneering liquid crystal researchers from the Department of Physics at the University of Colorado Boulder. When the prototype of the HS1 hot stage was built, their goal was to develop an instrument to meet the rigorous needs of their own academic research. The design of the HS1 was successful and resulted in the launching of Instec as a small garage-based company. Actually, to be honest, it was more like a toolbox in the corner of the garage. As the years progressed Instec expanded, first filling that garage to capacity, and then moving into its own design and manufacturing space. Instec's customer base also broadened from academic researchers to include scientists and engineers from government and industrial organizations around the globe.

In this catalog, you will find a complete line of thermal microscopy products designed for liquid crystal, polymer, biological, and materials sciences, as well as many other fields of research. Instec welcomes the opportunity to provide cost-effective and innovative solutions for its customers, and takes great pride in its ability to provide customized solutions for nearly any thermal control application.

Corporate longevity comes from customer satisfaction and Instec is honored to have a large base of satisfied customers. For over thirty years, Instec has continued in its effort to respond to the needs of the technical community with innovative and effective products. Commitment to customers will remain the driving force of Instec's continued success. We thank you, the customer, for the many opportunities you have provided over the years for Instec to service your research and development needs.

Hot & Cold Stages

Hot and Cold Stage Selection Chart	4
Hot and Cold Stage Application Guide	5
HCS302 Hot & Cold Stage	6
HCS302G Hot & Cold Gas-Tight Stage	8
HCS402 Hot & Cold Dual Heating Stage	10
HCS621G/V Gas/Vacuum-Tight Hot & Cold Stages	12
HCS622G/V Gas/Vacuum-Tight Hot & Cold Stages	14
TS102 Thermal Stage	16
TS102W Thermal Wide Aperture Stage	18
TS102G/V Thermal Gas/Vacuum-Tight Stages	20
TS104G Thermal Large Area Gas-Tight Stage	22
HCS321Gi Hot & Cold Gas-Tight Inverted Stage	24
HS1300G / HS1400G / HS1500G High Temperature Gas-Tight Hot Stages	26
CLM77K / CLM77Ki Cryo Stages	28
FS1 Microscope Hot & Cold Thin Film Drawing Stage	30

Accessories

Accessories Selection Guide	32
Liquid Nitrogen Cooling Systems	34
Water Cooling Accessories	36
Mounting Adapters	38
Spacer Kits & Micropositioner	39
Sample Holders	40
Long Working Distance Condenser	41
Microscope Camera With Temperature Overlay	42
mK2000 High Precision Temperature Controller	44

Technical Appendix

Glossary	46
-----------------	----

Instec's hot and cold stages provide a temperature-controlled environment for applications where optical access to a heated or cooled sample is required. Instec hot and cold stages are ideal for applications including microscopy, spectroscopy, FTIR, and X-ray scattering. Our standard products cover a temperature range from -190°C up to 1500°C depending on the model. On the following pages you will find stages designed primarily for upright and inverted microscopes. Stages can be ordered with special features such as vacuum or gas-tight chambers, extra-wide viewing apertures, and dual heating. The selection guide can help you to find a stage which meets your needs, but please do not hesitate contact us, as we may be able to recommend a better or more cost effective system. We are here to help! Our knowledgeable staff can discuss any special requirements you may have and recommend the most appropriate hot and cold stage or a possible custom solution.

Instec was founded by a group of physicists with the goal of creating highly flexible hot and cold stages. To this end, Instec stages come with a variety of features. Windows are removable and exchangeable, and all stages can be mounted both vertically and horizontally. Thus a stage used on an optical microscope one day can be placed in a spectrometer or even taken to an X-Ray beam line the next. Inner covers are included to improve temperature uniformity in single-heater stages. When temperature uniformity is more critical, dual heater stages are available which heat from both above and below the sample. To accommodate a variety of sample sizes, Instec stages come in many different sample chamber areas, and optional spacer sets are available for many models to increase the sample chamber height. In most stages, standard windows are made exceedingly thin to minimize optical aberrations and are built with a dual pane construction for improved thermal isolation and uniformity. For operation below ambient temperature, all Instec cold stages feature built-in gas defrost channels through which dry gas can be directed to prevent window fogging. All Instec stages are also capable of having their chambers purged with an inert gas. Some stage models feature side loading to allow for quick and easy sample exchange without moving or disturbing the microscope. This also allows for a sample on a standard microscope slide to be manually manipulated from outside of the stage. If more precise control is needed, a precision X-Y micrometer positioner is available.

All Instec thermal stages come configured with a stand-alone temperature controller. The mK2000 temperature controller offers 0.05°C temperature stability and 0.01°C temperature resolution for most Instec hot and cold stages. In addition, it offers a wealth of features such as built-in over-temperature protection and storage of user-defined temperature profiles. Our included thermal control software, WinTemp, logs and displays temperature vs. time plots and enables the quick and easy programming of almost any temperature profile. For those who want to integrate Instec temperature control into larger computer-controlled systems, we also offer free sample source code in LabVIEW and C++. For more information on the mK2000, please refer to the Accessories section of this catalog.

Hot & Cold Stage Selection Guide

Description



Below we have provided a basic guide summarizing the distinguishing features of our hot and cold stage models. The table lists the temperature ranges and sample areas available, along with special features such as Dual Heaters, Peltier Cooling, Vacuum, Wide Aperture, and X-Y sample micropositioner.

Model	Temperature Range ¹	Sample Area	Dual Heaters ²	Peltier Cooling ³	Vacuum/ Gas-tight	Inverted ⁴	Wide Aperture	X-Y Available
HCS302	-190°C to 400°C	38 mm x 50 mm ¹						●
HCS302G	-190°C to 400°C	38 mm x 50 mm			G			●
HCS402	-190°C to 400°C	38 mm x 50 mm ¹	●					●
HCS621G/V	-190°C to 600°C	22 mm x 22mm			G/V			●
HCS622G/V	-190°C to 600°C	38 mm x 38 mm			G/V			●
TS102	-30°C to 90°C	38 mm x 50 mm ¹		●				●
TS102W	-30°C to 90°C	38 mm x 50 mm ¹		●			●	●
TS102G/V	-40°C to 120°C	25 mm x 75 mm ¹		●	G/V			
TS104G	-30°C to 90°C	97 mm x 97 mm ¹		●	G			
HCS321Gi	-80°C to 250°C	27 mm x 22 mm			G	●		
HS1300G	Ambient to 1300°C	16 mm x 16 mm			G			●
HS1400G	Ambient to 1400°C	16 mm x 16 mm			G			●
HS1500G	Ambient to 1500°C	16 mm x 16 mm			G			
CLM77K	-190°C to 120°C	Nine 3 mm diameter grids						●
CLM77Ki	-190°C to 120°C	Nine 3 mm diameter grids				●		●
FS1	-60°C to 200°C	38 mm x 58 mm	●					●

1. Side loading model or can accommodate a 25 mm x 75 mm slide.
2. Dual Heaters: Hot and Cold Stage model has dual heaters located both below and above the sample chamber, which provides ultra temperature uniformity.
3. Peltier Cooling: Thermal Stage models use the thermoelectric effect for heating and cooling and do not require additional sample chamber cooling accessories (i.e. no LN2-SYS Liquid Nitrogen Cooling Accessory).
4. Hot and cold stages designed specifically for inverted microscopes.

Below we have provided a basic guide to help you in selecting a hot and cold stage based on your application. Please remember that this guide does not list every option available for each category. For example, nearly all of Instec's hot and cold stages can be used for liquid crystals and polymers. We have simply listed the most popular stages for the category. Your final selection from Instec's hot and cold stages will depend on your specific application. To confirm that the selected stage is appropriate for your application please email us your requirements, such as research area, sample size, temperature range, type of microscope or other equipment to be used with this hot and cold stage, and environmental control requirements (i.e. vacuum or gas purge).

	General Purpose	Liquid Crystal & Polymer	Biology/Cryobiology	Spectroscopy	Pharmaceuticals	X-Ray Diffraction	Nanophotonics	Geology/Fluid Inclusion	Freeze Drying	Inverted Microscope	Freely Suspended Films	Food Sciences	Materials Science
HCS302 ¹	•	•		•	•	•	•	•				•	•
HCS302G	•	•		•	•	•		•				•	•
HCS402 ¹	•	•		•	•	•	•					•	•
HCS621G/V	•			•		•	•	•	•				•
HCS622G/V	•			•		•	•	•	•				•
TS102 ¹	•	•	•	•	•	•	•					•	•
TS102W ¹	•	•	•	•		•							•
TS102G/V ¹	•	•	•	•		•			•			•	•
TS104G ¹	•	•											•
HCS321Gi	•		•		•					•			
HS1300G				•		•		•					•
HS1400G				•		•		•					•
HS1500G				•		•		•					•
CLM77K			•										
CLM77Ki			•							•			
FS1		•									•		

1. The sample chamber can accommodate a 25 mm x 75 mm slide.

Instec's HCS302 offers a temperature controlled environment that is an ideal choice for optical thermal microscopy and other applications requiring optical access to the sample. Top and bottom dual pane windows on the HCS302 stage are removable and exchangeable to meet a range of spectroscopic needs. The stage can be mounted vertically, allowing horizontal beam access to the sample chamber. The HCS302 is large enough to accommodate a variety of samples, including electro-optic devices and standard 25 mm x 75 mm microscope slides. An inner thermal cover is also included for work requiring ultra-high temperature stability and uniformity.

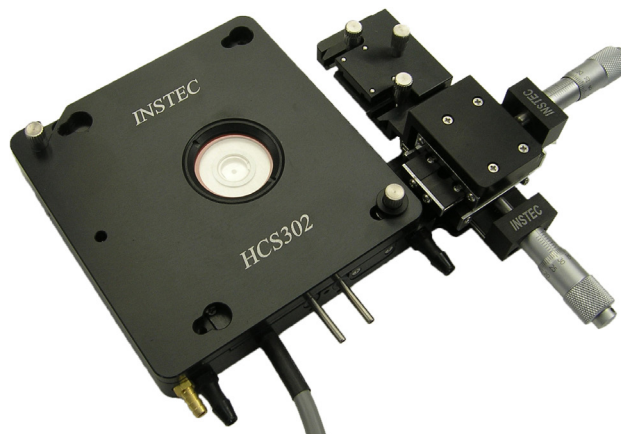

The HCS302 offers exceptional versatility at an excellent price!

Features

- Programmable precision temperature from -190°C to 400°C
- Swing cover for easy sample access
- Removable and exchangeable dual pane windows
- Integrated aperture window defrost system
- Available spacers for variable sample chamber height
- Gas purge sample chamber
- Inner cover for improved sample temperature uniformity
- Easy side sample loading
- Accommodates standard microscope slides
- Vertical and horizontal mounting points
- Optional microscope stage mounting adapters available
- Optional precision X-Y micropositioner for in situ sample positioning (pictured)

Technical Specifications

Temperature Range	-190°C to 400°C [†] Below ambient operation requires optional cooling accessory
Temperature Resolution	0.01°C
Temperature Stability	±0.05°C at 100°C (better stability optional)
Minimum Heating and Cooling Rate	±0.1°C per hour
Maximum Heating Rate	+100°C per minute at 100°C
Maximum Cooling Rate	-60°C per minute at 100°C
Temperature Control Method	Switching PID
Temperature Control Sensor	100 Ω Platinum RTD
Minimum Objective Working Distance	5.3 mm
Minimum Condenser Working Distance	10.3 mm
Sample Area	38 mm x 50 mm
Chamber Height	2 mm with inner cover in place (up to 8 mm when using spacers)
Sample Viewing Aperture	2 mm for transmitted light; 26.5 mm for reflected light
X-Y Micropositioner (optional)	10 μm resolution
Weight	670 g

*Sample area and sample viewing aperture specifications given without inner cover in place. Working distances will be greater if optional spacers are used. 5, 8 or 10 mm aperture for transmitted light available by request.

[†]Installation of frame skirt is required for stage operation below -60°C so that water condensation does not collect inside the sample chamber. When the skirt is in place, side loading of sample and XY positioning are not possible.

Ordering Information

Part Number	Description
HCS302-mK2000	HCS302, hot and cold stage with mK2000, 115V/230V, software included
XY-A-01	Precision X-Y Micropositioner with sample holder and accessories
SP06-A-01	1.5 mm spacer set to increase sample chamber height
SP12-A-01	3.0 mm spacer set to increase sample chamber height

Please refer to Accessories section for mK2000 temperature controller options, cooling accessories, mounting adapters, and microscope accessories.

Physical Dimensions and Mechanical Drawings

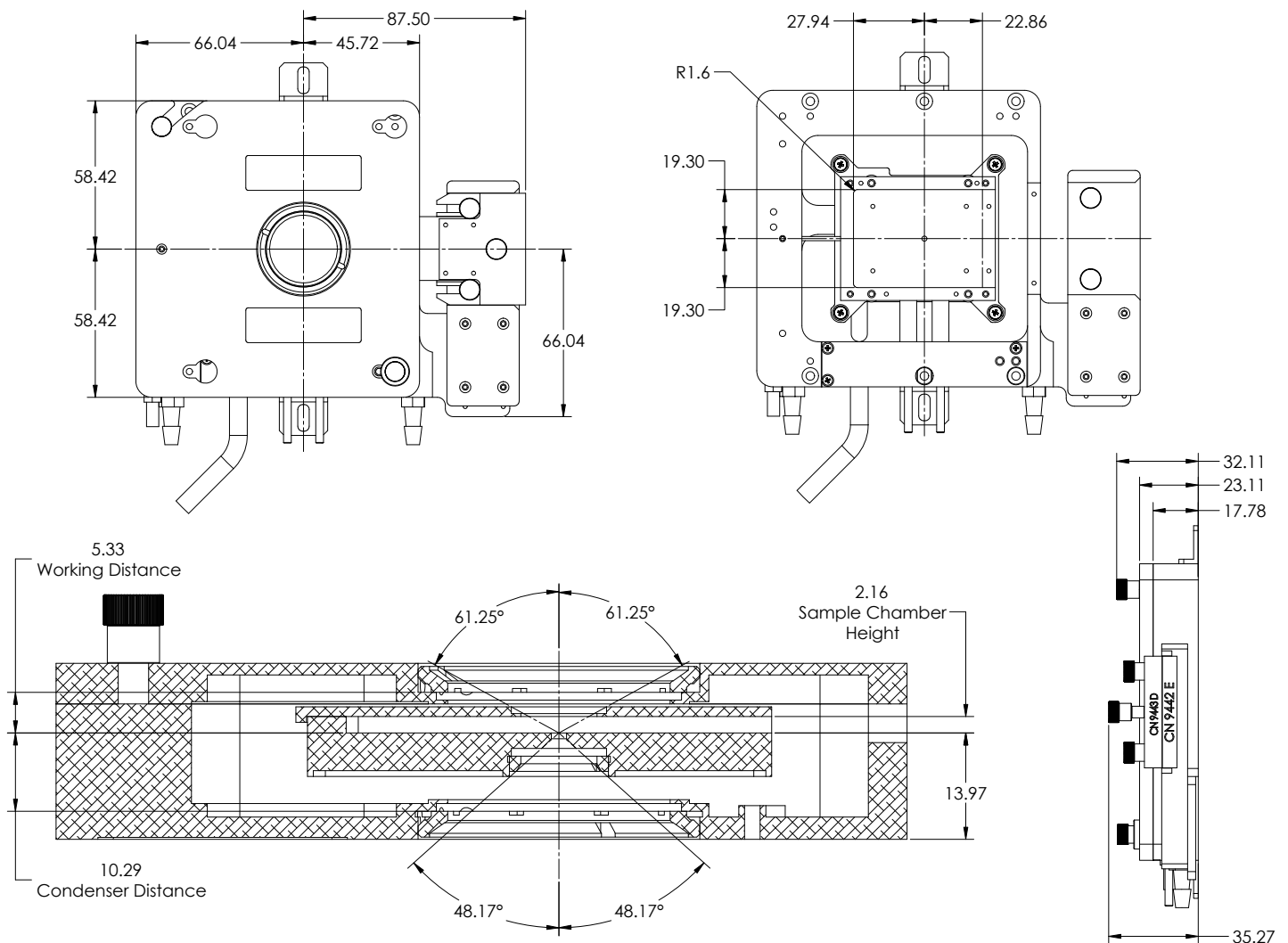

HCS302G

Hot & Cold Gas-Tight Stage



The HCS302G features a gas-tight sample chamber which can be gas purged to prevent condensation or to make measurements under a controlled atmosphere and at a set temperature. Top and bottom dual pane windows on the HCS302G stage are removable and exchangeable to meet a range of spectroscopic needs. The stage can be mounted vertically, allowing horizontal beam access to the sample chamber. An inner thermal cover is also included for work requiring ultra-high temperature stability and uniformity.

The HCS302G is a versatile and budget-friendly option for experiments requiring atmospheric control.

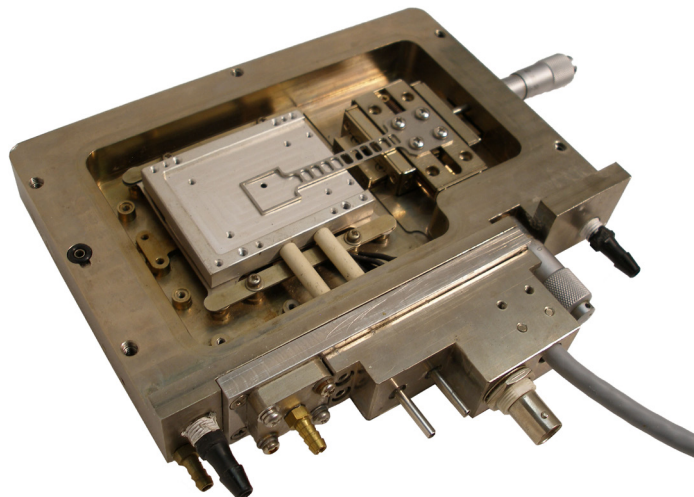

HCS302GXY pictured above

Features

- Programmable precision temperature from -190°C to 400°C
- Gas-tight sample chamber
- Removable and exchangeable windows
- Integrated aperture window defrost system
- Inner cover for improved sample temperature uniformity
- Vertical and horizontal mounting points
- Optional microscope stage mounting adapters available

Technical Specifications

Temperature Range	-190°C to 400°C Below ambient operation requires optional cooling accessory
Temperature Resolution	0.01°C
Temperature Stability	±0.05°C at 100°C (better stability optional)
Minimum Heating and Cooling Rate	±0.1°C per hour
Maximum Heating Rate	+100°C per minute at 100°C
Maximum Cooling Rate	-60°C per minute at 100°C
Temperature Control Method	Switching PID
Temperature Control Sensor	100 Ω Platinum RTD
Minimum Objective Working Distance	6.2 mm
Minimum Condenser Working Distance	13 mm
Sample Area	38 mm x 50 mm
Chamber Height	4.5 mm
Sample Viewing Aperture	2 mm for transmitted light; 26.5 mm for reflected light
Weight	1080 g; 1,460 g with XY

*Sample area, chamber height and sample viewing aperture specifications given without inner cover in place. 5, 8 or 10 mm aperture for transmitted light available by request.

Ordering Information

Part Number	Description
HCS302G-mK2000	HCS302, gas-tight hot and cold stage with mK2000, 115V/230V, software included
HCS302GXY-mK2000	HCS302, gas-tight hot and cold stage with mK2000, precision X-Y micropositioner, 115V/230V, software included

Please refer to Accessories section for mK2000 temperature controller options, cooling accessories, mounting adapters, and microscope accessories.

Physical Dimensions and Mechanical Drawings

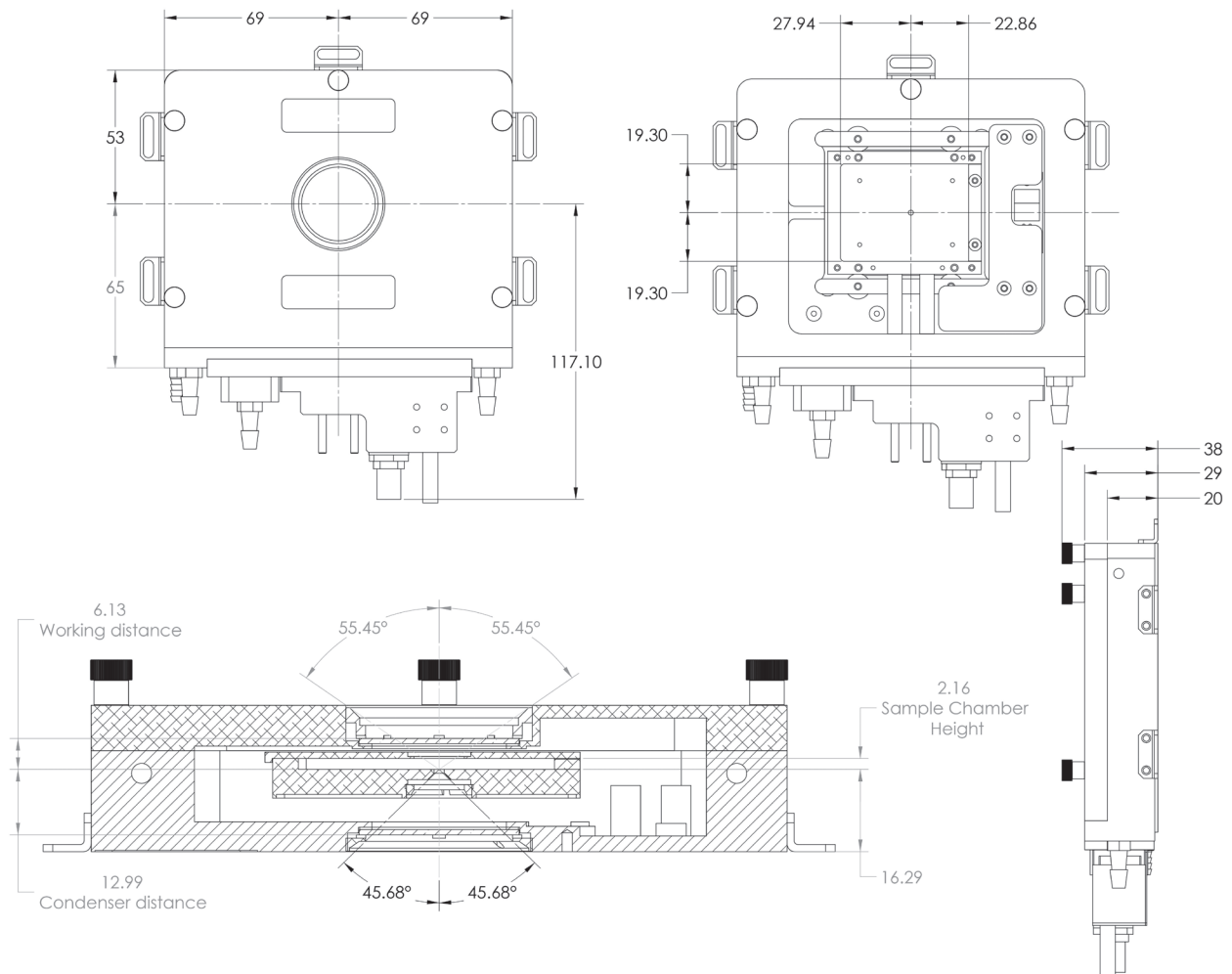

*HCS302G pictured. Contact Instec for information on HCS302GXY.

HCS402

Dual Heating Hot & Cold Stage



Instec's HCS402 microscope hot and cold stage features a dual heater design which virtually eliminates vertical temperature gradients in the sample chamber. This makes the HCS402 temperature controlled environment an ideal choice for thicker samples or when the best available temperature uniformity is necessary. Top and bottom dual pane windows on the HCS402 stage are removable and exchangeable to meet a range of spectroscopic needs. The stage can be mounted vertically for applications requiring horizontal beam access to the sample chamber. The interior of the HCS402 is large enough to accommodate a variety of samples, including electro-optic devices and standard 25 mm x 75 mm microscope slides.



The integrated top cover heater provides supreme above-ambient temperature stability and uniformity. A must have for precision experiments!

Features

- Programmable precision temperature from -190°C to 400°C†
- Dual heaters located above and below the sample chamber for superior temperature uniformity
- Removable and exchangeable windows
- Dual pane windows for better thermal isolation
- Integrated aperture window defrost system
- Available spacers for variable sample chamber height
- Gas purge sample chamber
- Easy side sample loading with standard microscope slides
- Vertical and horizontal mounting
- Optional microscope rotational stage mounting adapters available
- Optional precision X-Y micropositioner for in situ sample positioning

Technical Specifications

Temperature Range	-190°C to 400°C Below ambient operation requires optional cooling accessory
Temperature Resolution	0.01°C
Temperature Stability	±0.05°C at 100°C (better stability optional)
Minimum Heating and Cooling Rate	±0.1°C per hour
Maximum Heating Rate	+150°C per minute at 100°C
Maximum Cooling Rate	-50°C per minute at 100°C
Temperature Control Method	Switching PID
Temperature Control Sensor	100 Ω Platinum RTD
Minimum Objective Working Distance	7.9 mm
Minimum Condenser Working Distance	10.3 mm
Sample Area	38 mm x 50 mm
Chamber Height	2 mm (up to 8 mm when using spacers)
Sample Viewing Aperture	2 mm for transmitted light; 10 mm for reflected light
X-Y Micropositioner (optional)	10 μm resolution
Weight	780 g

*Working distances will be greater if optional spacers are used. 5, 8 or 10 mm aperture for transmitted light available by request.

†Installation of frame skirt is required for stage operation below -60°C so that water condensation does not collect inside the sample chamber. When the skirt is in place, side loading of sample and XY positioning are not possible.

Ordering Information

Part Number	Description
HCS402-mK2000	HCS402, dual heater, hot and cold stage with mK2000, 115V/230V, software included
XY-A-01	Precision X-Y Micropositioner with sample holders and accessories
SP06-A-01	1.5 mm spacer set to increase sample chamber height, for HCS302, HCS402, HCS412W
SP12-A-01	3.0 mm spacer set to increase sample chamber height, for HCS302, HCS402, HCS412W
SP40-A-01	10.0 mm spacer set to increase sample chamber height for HCS402

Please refer to Accessories section for mK2000 temperature controller options, cooling accessories, mounting adapters, and microscope accessories.

Physical Dimensions and Mechanical Drawings

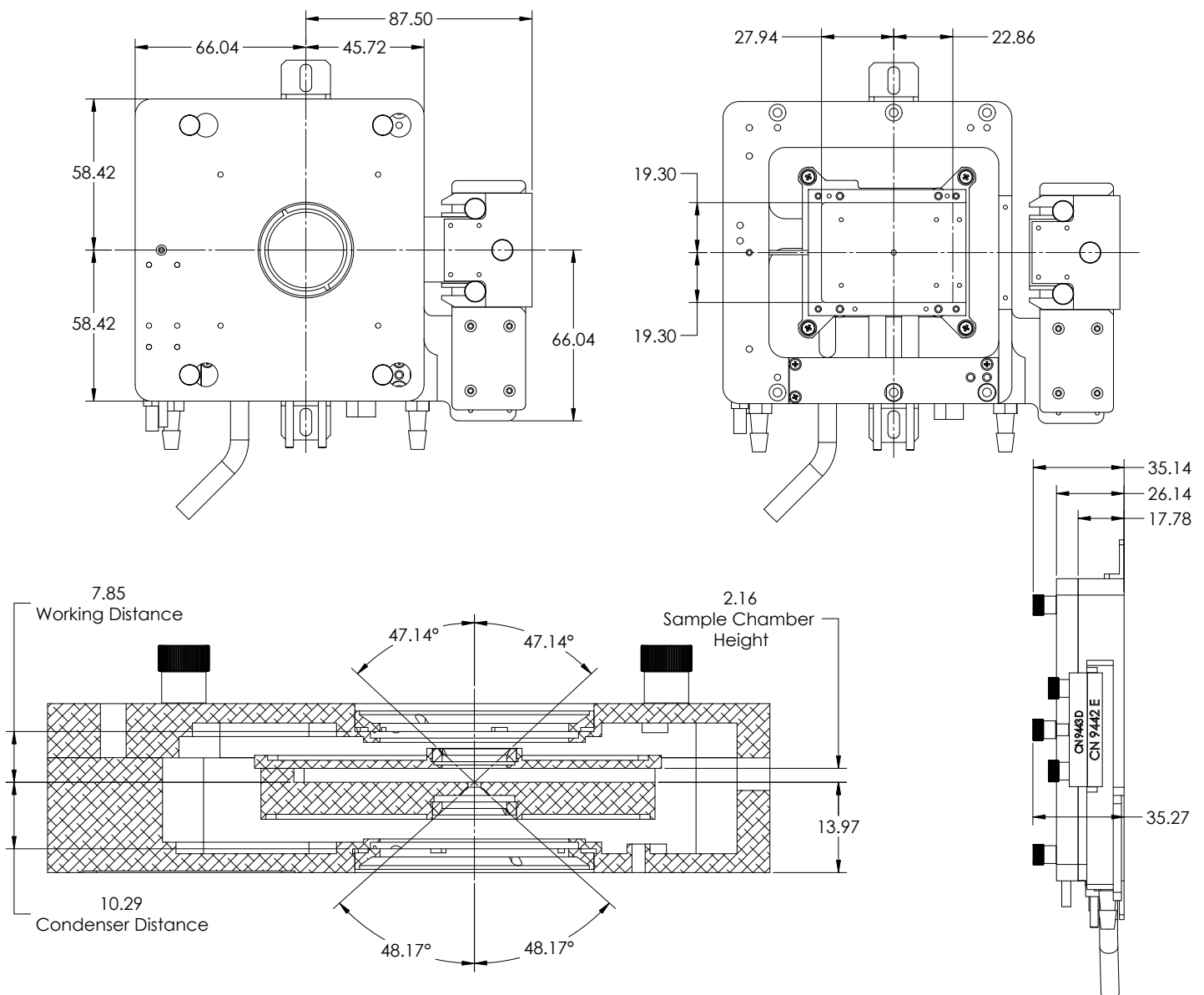

HCS621G/V

Gas/Vacuum-Tight Hot & Cold Stages



Instec's HCS621 series vacuum and gas-tight stages are designed for applications where a wide temperature range is needed and control over the atmosphere is critical. This series features a silver heating and cooling block, providing the user with exceptional temperature uniformity. The gas-tight configuration provides a sealed chamber for gas purge to avoid condensation or oxidation. The vacuum-tight models can be both gas purged and evacuated to low pressures to protect sensitive samples from moisture and oxygen and to study vacuum processes such as freeze drying. Options are available including X-Y sample positioning, and up to 8 electric feedthroughs for sample connection and probing.

High performance across a very large temperature range.

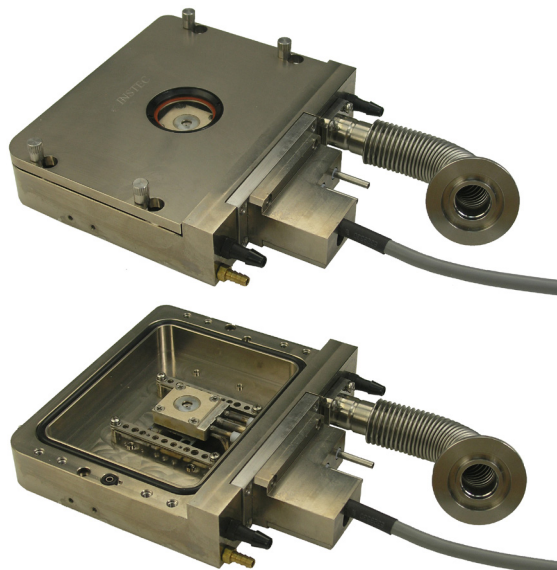

HCS621V pictured above

Features

- Programmable precision temperature from -190°C to 600°C
- Gas or vacuum-tight sample chamber
- Optional 2, 4 or 8 electric feedthroughs for sample probing
- Large viewing aperture for reflected light
- Removable and exchangeable windows
- Integrated aperture window defrost system
- Vertical and horizontal mounting
- Optional microscope stage mounting adapters available
- Optional precision X-Y micropositioner for in situ sample positioning

Technical Specifications

Temperature Range	-190°C to 600°C Below ambient operation requires optional cooling accessory
Temperature Resolution	0.01°C
Temperature Stability	±0.05°C at 100°C (better stability optional)
Minimum Heating and Cooling Rate	±0.1°C per hour
Maximum Heating Rate	+140°C per minute at 100°C
Maximum Cooling Rate	-55°C per minute at 100°C
Temperature Control Method	Switching PID
Temperature Control Sensor	100 Ω Platinum RTD
Minimum Objective Working Distance	5.5 mm, 5.2 mm with XY
Minimum Condenser Working Distance	15.4 mm, 11.8 mm with XY
Sample Area	22 mm x 22 mm
Chamber Height	3 mm
Sample Viewing Aperture	1.3 mm (1.5 mm with XY) for transmitted light ; 26.5 mm for reflected light
Vacuum Port (vacuum-tight models)	KF25
X-Y Micropositioner (optional)	10 μm resolution
Weight	1010 g; 1290 g with XY

*Sample area, chamber height and sample viewing aperture specifications given without inner cover in place.

Ordering Information

Part Number	Description
HCS621G-mK2000	HCS621G gas-tight hot and cold stage with mK2000, 115V/230V, software included
HCS621V-mK2000	HCS621V vacuum-tight hot and cold stage with mK2000, 115V/230V, software included
HCS621GXY-mK2000	HCS621GXY gas-tight hot and cold stage with mK2000, precision X-Y micropositioner, 115V/230V, software included
HCS621VXY-mK2000	HCS621VXY vacuum-tight hot and cold stage with mK2000, precision X-Y micropositioner, 115V/230V, software included
F2/4/8-C-01	Two/Four/Eight sealed electric feedthroughs, can only be ordered with a stage or plate

Please refer to Accessories section for mK2000 temperature controller options, cooling accessories, mounting adapters, and microscope accessories.

Physical Dimensions and Mechanical Drawings

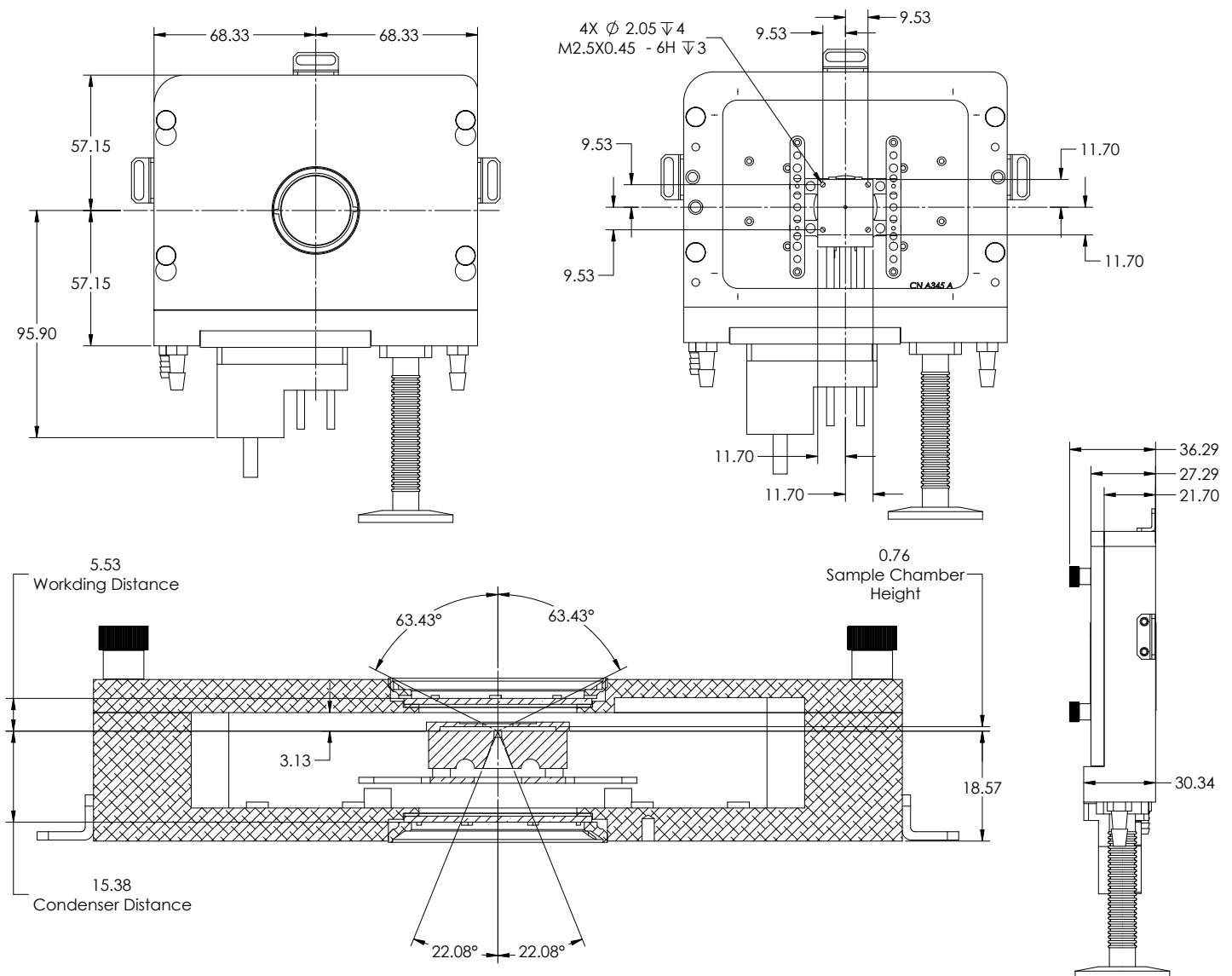

*HCS621V pictured. Contact Instec for information on other models.

HCS622G/V

Gas/Vacuum-Tight Hot & Cold Stages



Instec's HCS622 series vacuum and gas-tight stages are designed for applications where a wide temperature range is needed and control over the atmosphere is critical. This series features a silver heating and cooling block, providing the user with exceptional temperature uniformity. The gas-tight configuration provides a sealed chamber for gas purge to avoid condensation or oxidation. The vacuum-tight models can be both gas purged and evacuated to low pressures to protect sensitive samples from moisture and oxygen and to study vacuum processes such as freeze drying. Options are available for up to 8 electric feedthroughs for sample connection and probing.

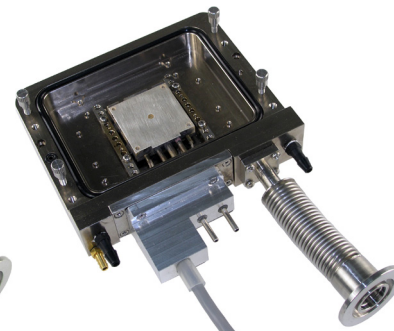

HCS622V pictured above

Features

- Programmable precision temperature from -190°C to 600°C
- Gas or vacuum-tight sample chamber
- Optional 2 to 8 electric feedthroughs for sample contact & measurement
- Large viewing aperture for reflected light
- Removable and exchangeable windows
- Integrated aperture window defrost system
- Vertical and horizontal mounting

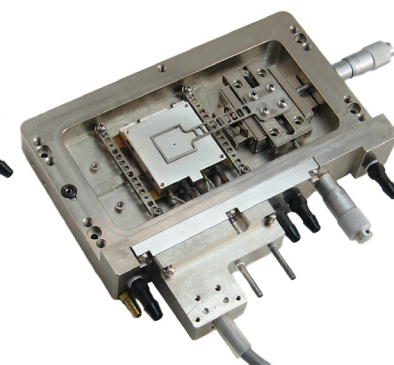

HCS622GXY pictured above

Technical Specifications

Temperature Range	-190°C to 600°C Below ambient operation requires optional cooling accessory
Temperature Resolution	0.01°C
Temperature Stability	±0.05°C at 100°C (better stability optional)
Minimum Heating and Cooling Rate	±0.1°C per hour
Maximum Heating Rate	+180°C per minute at 100°C
Maximum Cooling Rate	-60°C per minute at 100°C
Temperature Control Method	Switching PID
Temperature Control Sensor	100 Ω Platinum RTD
Minimum Objective Working Distance	5.5 mm; 5.2 mm with XY
Minimum Condenser Working Distance	15.4 mm; 11.8 with XY
Sample Area	38 mm x 38 mm
Chamber Height	3 mm
Sample Viewing Aperture	1.3 mm (1.5 mm with XY) for transmitted light; 26.5 mm for reflected light
Vacuum Port (vacuum-tight models)	KF25
X-Y Micropositioner (optional)	10 μm resolution
Weight	1050g; 1350 g with XY

*Sample area, chamber height and sample viewing aperture specifications given without inner cover in place.

Ordering Information

Part Number	Description
HCS622G-mK2000	HCS622G gas-tight hot and cold stage with mK2000, 115V/230V, software included
HCS622V-mK2000	HCS622V vacuum-tight hot and cold stage with mK2000, 115V/230V, software included
HCS622GXY-mK2000	HCS622GXY gas-tight hot and cold stage with mK2000, precision X-Y micropositioner, 115V/230V, software included
HCS622VXY-mK2000	HCS622VXY vacuum-tight hot and cold stage with mK2000, precision X-Y micropositioner, 115V/230V, software included
F2/4/8-C-01	Two/Four/Eight sealed electric feedthroughs, can only be ordered with a stage or plate

Please refer to Accessories section for mK2000 temperature controller options, cooling accessories, mounting adapters, and microscope accessories.

Physical Dimensions and Mechanical Drawings

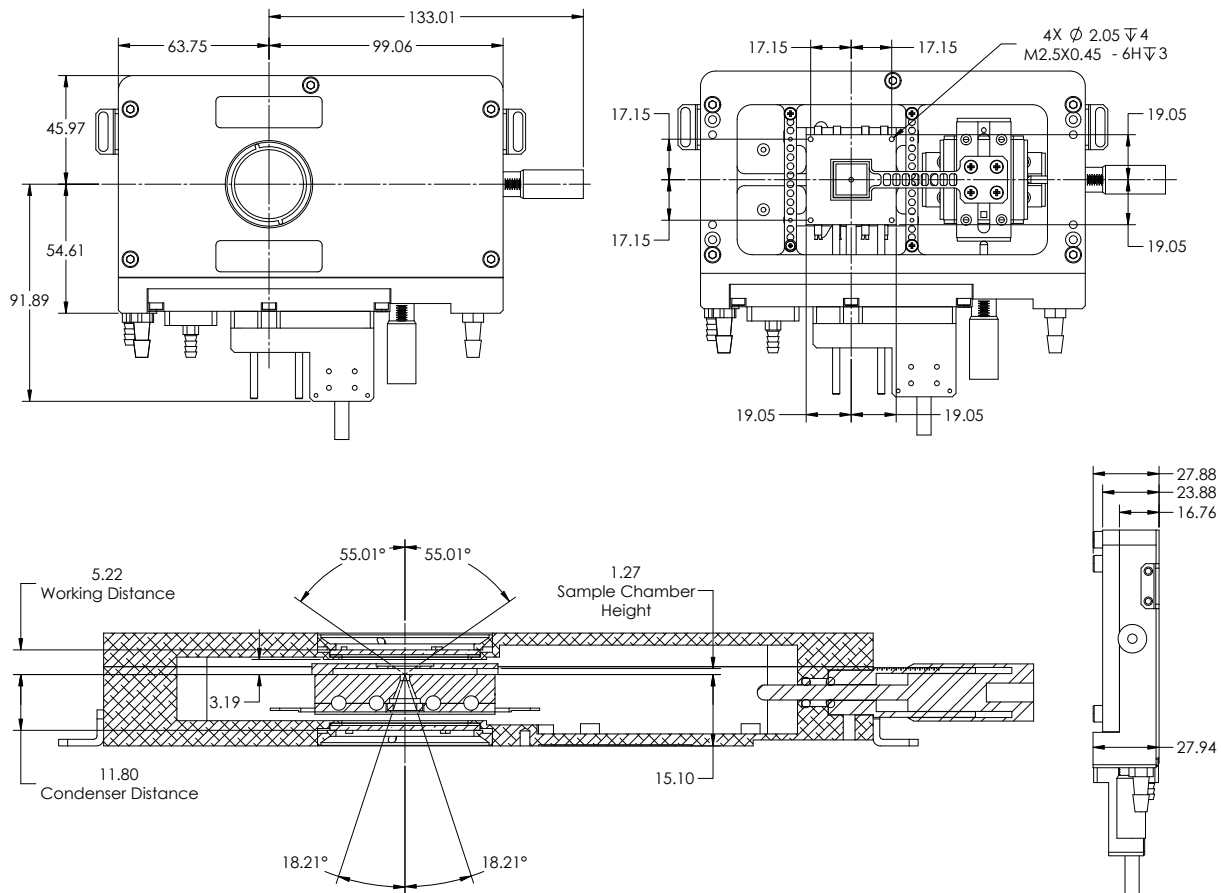

*HCS622GXY pictured. Contact Instec for information on other models.

TS102

Thermal Stage

Instec's TS102 is our thermoelectric (Peltier) based stage that can provide cooling to -30°C without using liquid nitrogen or a recirculating chiller. This simplifies the system set up, reduces operating costs, and makes it a convenient choice for performing long duration experiments at low temperatures. The TS102 features convenient side loading of samples and accommodates standard microscope slides as well as Instec liquid crystal cell holders.

The TS102 is a perfect choice for researchers needing both heating and cooling over a moderate temperature range.



Features

- Programmable precision temperature from -30°C to 90°C
- Peltier-based thermal stage
- Controlled fast heating and cooling rate
- Removable and exchangeable windows
- Integrated aperture window defrost system
- Gas purge sample chamber
- Inner cover for improved sample temperature uniformity
- Vertical and horizontal mounting
- Optional precision X-Y micropositioner for in situ sample positioning

Technical Specifications

Temperature Range	-30°C to 90°C
Temperature Resolution	0.01°C
Temperature Stability	$\pm 0.05^{\circ}\text{C}$ at 100°C
Minimum Heating and Cooling Rate	$\pm 0.1^{\circ}\text{C}$ per hour
Maximum Heating Rate	$50^{\circ}\text{C}/\text{minute}$ at 37°C
Maximum Cooling Rate	$-30^{\circ}\text{C}/\text{minute}$ at 37°C
Temperature Control Method	Switching PID
Temperature Control Sensor	$100\ \Omega$ Platinum RTD
Minimum Objective Working Distance	8 mm
Minimum Condenser Working Distance	8.6 mm
Sample Area	38 mm x 50 mm
Chamber Height	6.4 mm
Sample Viewing Aperture	2 mm for transmitted light; 38.5 mm for reflected light
X-Y Micropositioner (optional)	$10\ \mu\text{m}$ resolution
Weight	990 g

*Sample area, chamber height and sample viewing aperture specifications given without inner cover in place. 5 or 8 mm aperture for transmitted light available by request.

Ordering Information

Part Number	Description
TS102-mK2000	TS102, thermal stage with mK2000, 115V/230V, software included
XY-A-01	Precision X-Y Micropositioner with sample holders and accessories

Please refer to Accessories section for mK2000 temperature controller options, cooling accessories, mounting adapters, and microscope accessories.

Physical Dimensions and Mechanical Drawings

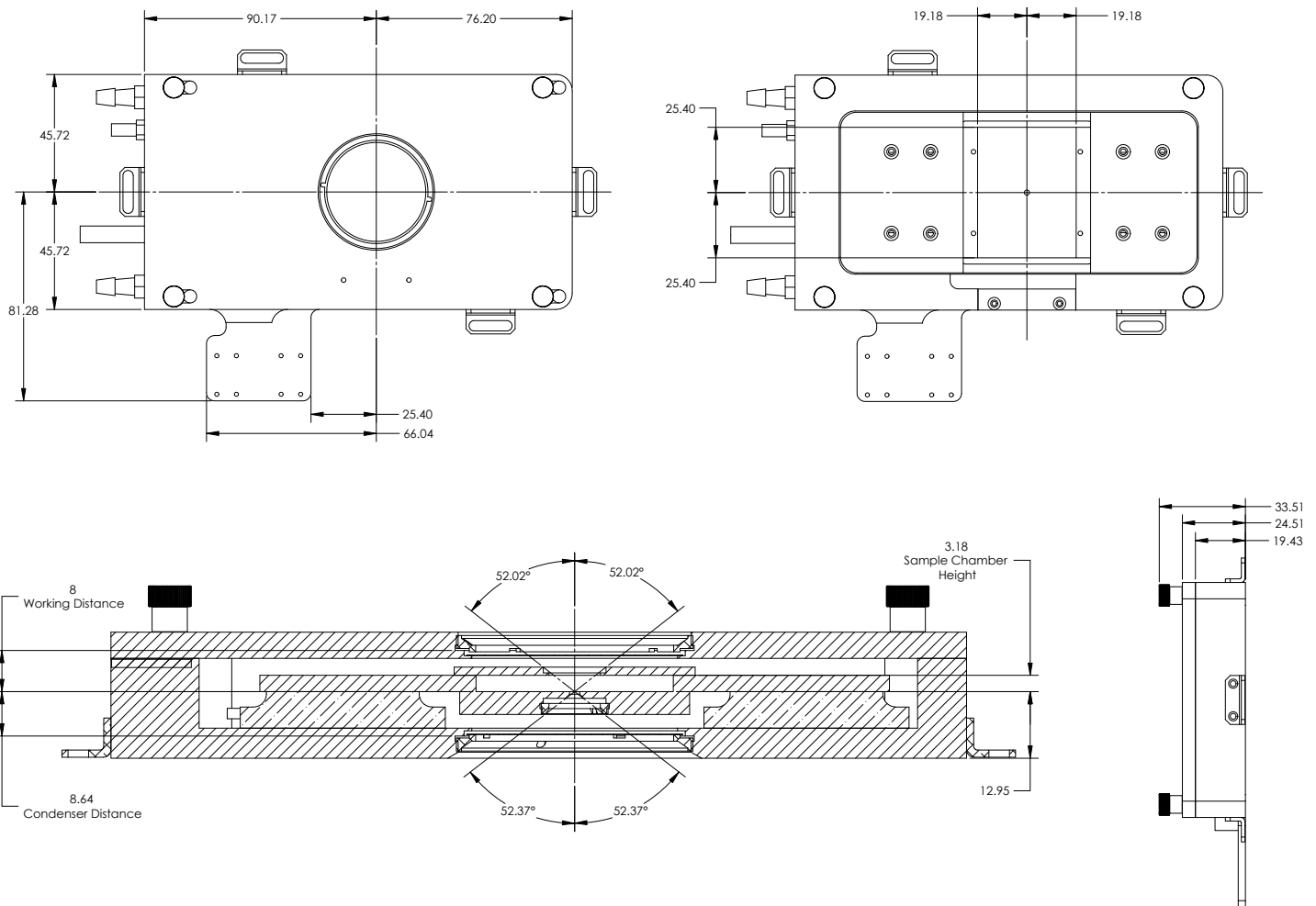

TS102W

Thermal Wide Aperture Stage



Instec's TS102W is a thermoelectric (Peltier) based stage providing cooling to -30°C without using liquid nitrogen or a recirculating chiller. This simplifies the system set up, reduces operating costs, and makes it a convenient choice for performing long duration experiments at low temperatures. The TS102W features a large viewing aperture for transmitted light, and access to incident angles up to 60° for wide angle X-ray and light scattering experiments.



Features

- Programmable precision temperature from -30°C to 90°C
- Peltier-based thermal microscope stage
- Controlled fast heating and cooling rate
- Accommodates up to a 38 mm x 50 mm sample size
- Wide incident angle up to 60°
- Extra large viewing aperture
- Removable and exchangeable windows
- Dual pane windows for better thermal isolation
- Integrated aperture window defrost system
- Variable sample chamber height
- Gas purge sample chamber
- Inner cover for improved sample temperature uniformity
- Easy side sample loading with standard microscope slides
- Vertical and horizontal mounting
- Optional precision X-Y micropositioner for in situ sample positioning (pictured)

Technical Specifications

Temperature Range	-30°C to 90°C
Temperature Resolution	0.01°C
Temperature Stability	$\pm 0.05^{\circ}\text{C}$ at 37°C (better stability optional)
Minimum Heating and Cooling Rate	$\pm 0.1^{\circ}\text{C}$ per hour
Maximum Heating Rate	$+50^{\circ}\text{C}$ per minute at 37°C
Maximum Cooling Rate	-30°C per minute at 37°C
Temperature Control Method	PID with Linear Variable DC
Temperature Control Sensor	100 Ω Platinum RTD
Minimum Objective Working Distance	8 mm
Minimum Condenser Working Distance	8.6 mm
Sample Area	38 mm x 50 mm
Chamber Height	3 mm
Sample Viewing Aperture	10 mm for transmitted light; 38.5 mm for reflected light
X-Y Micropositioner (optional)	10 μm resolution
Weight	990 g

*Sample area, chamber height and sample viewing aperture specifications given without inner cover in place. 20 mm aperture for transmitted light available by request.

Ordering Information

Part Number	Description
TS102W-mK2000	TS102W, Wide Aperture Microscope Thermal Stage with mK2000, 115V/230V, software included
XY-A-01	Precision X-Y Micropositioner with sample holder and accessories

Please refer to Accessories section for mK2000 temperature controller options, cooling accessories, mounting adapters, and microscope accessories.

Physical Dimensions and Mechanical Drawings

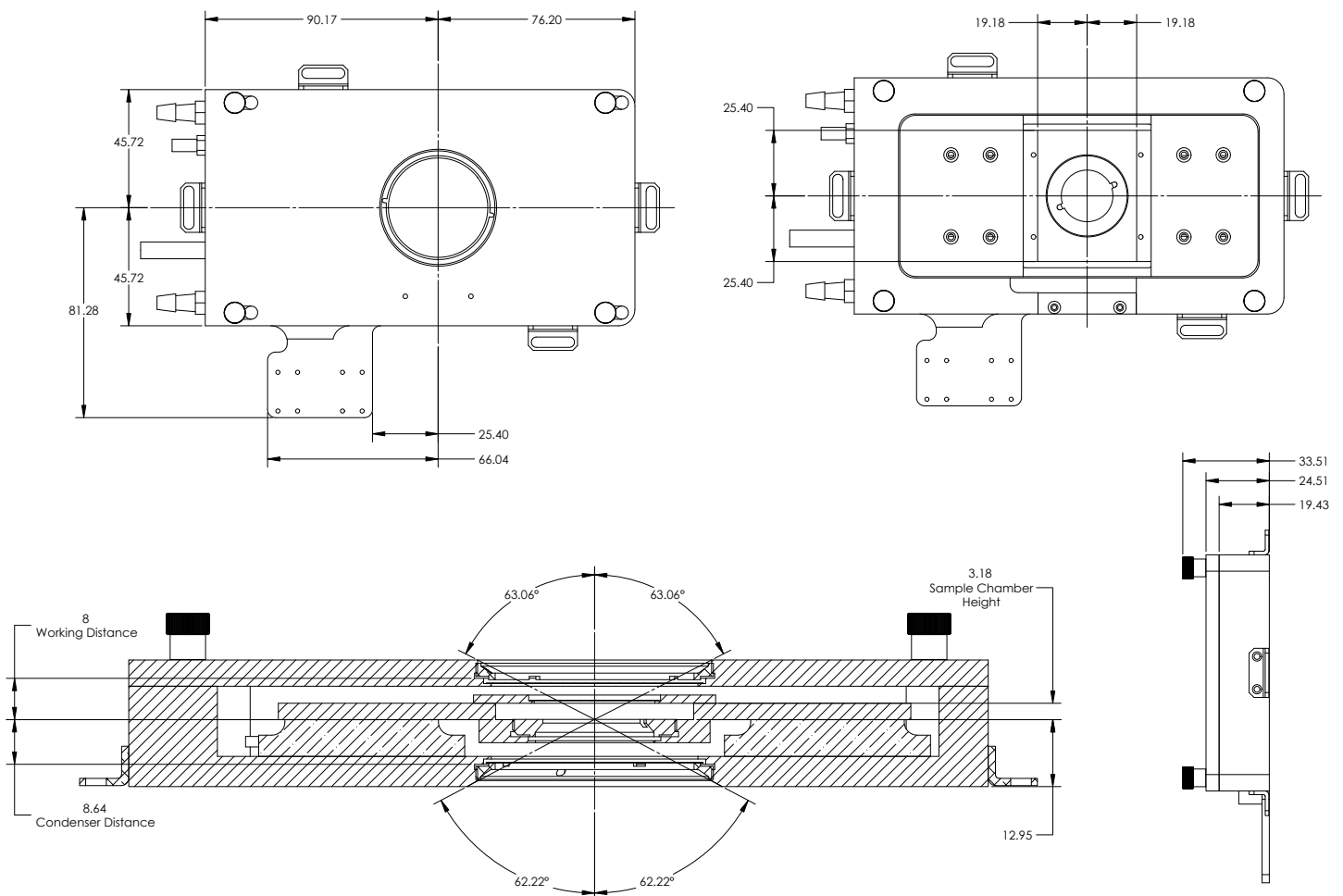

TS102G/V

Thermal Gas/Vacuum-Tight Stages



Instec's TS102 series thermoelectric (Peltier) based thermal vacuum and gas-tight stages provide cooling to -40°C without using liquid nitrogen or a recirculating chiller. This simplifies the system set up, reduces operating costs, and makes it a convenient choice for performing long duration experiments at low temperatures. The TS102V with vacuum chamber capability is ideal for freeze drying samples under a microscope. The TS102G is a lower cost option for controlling the atmosphere when vacuum is not required.



TS102G pictured above

Features

- Programmable precision temperature from -40°C to 120°C Peltier based thermal stage with sealed vacuum or gas-tight sample chamber
- Optional two electric feedthroughs for sample probing
- Controlled fast heating and cooling rate
- Removable and exchangeable windows
- Integrated aperture window defrost system
- Inner cover for improved sample temperature uniformity
- Vertical and horizontal mounting

Technical Specifications

Temperature Range	-40°C to 120°C
Temperature Resolution	0.01°C
Temperature Stability	$\pm 0.05^{\circ}\text{C}$ at 37°C (higher stability optional)
Minimum Heating and Cooling Rate	$\pm 0.1^{\circ}\text{C}$ per hour
Maximum Heating Rate	$+80^{\circ}\text{C}$ per minute at 37°C
Maximum Cooling Rate	-35°C per minute at 37°C
Temperature Control Method	PID with Linear Variable DC
Temperature Control Sensor	100 Ω Platinum RTD
Minimum Objective Working Distance	5.1 mm
Minimum Condenser Working Distance	17.5 mm
Sample Area	25 mm x 75 mm
Chamber Height	3.5 mm
Sample Viewing Aperture	2 mm for transmitted light; 26.5 mm (G) / 38.5 mm (V) for reflected light
Vacuum Port	KF25
Weight	1,150 g (G) / 1,210 g (V)

*Sample area, chamber height and sample viewing aperture specifications given without inner cover in place. 5 or 8 mm aperture for transmitted light available by request.

Ordering Information

Part Number	Description
TS102G-mK2000	TS102G, gas-tight thermal stage with mK2000, 115V/230V, software included
TS102V-mK2000	TS102V, vacuum-tight thermal stage with mK2000, 115V/230V, WP115F or WP230F and software included
F2-C-01	Two sealed electric feedthroughs, can only be ordered with hot and cold stage/plate

Please refer to Accessories section for mK2000 temperature controller options, cooling accessories, mounting adapters, and microscope accessories.

Physical Dimensions and Mechanical Drawings

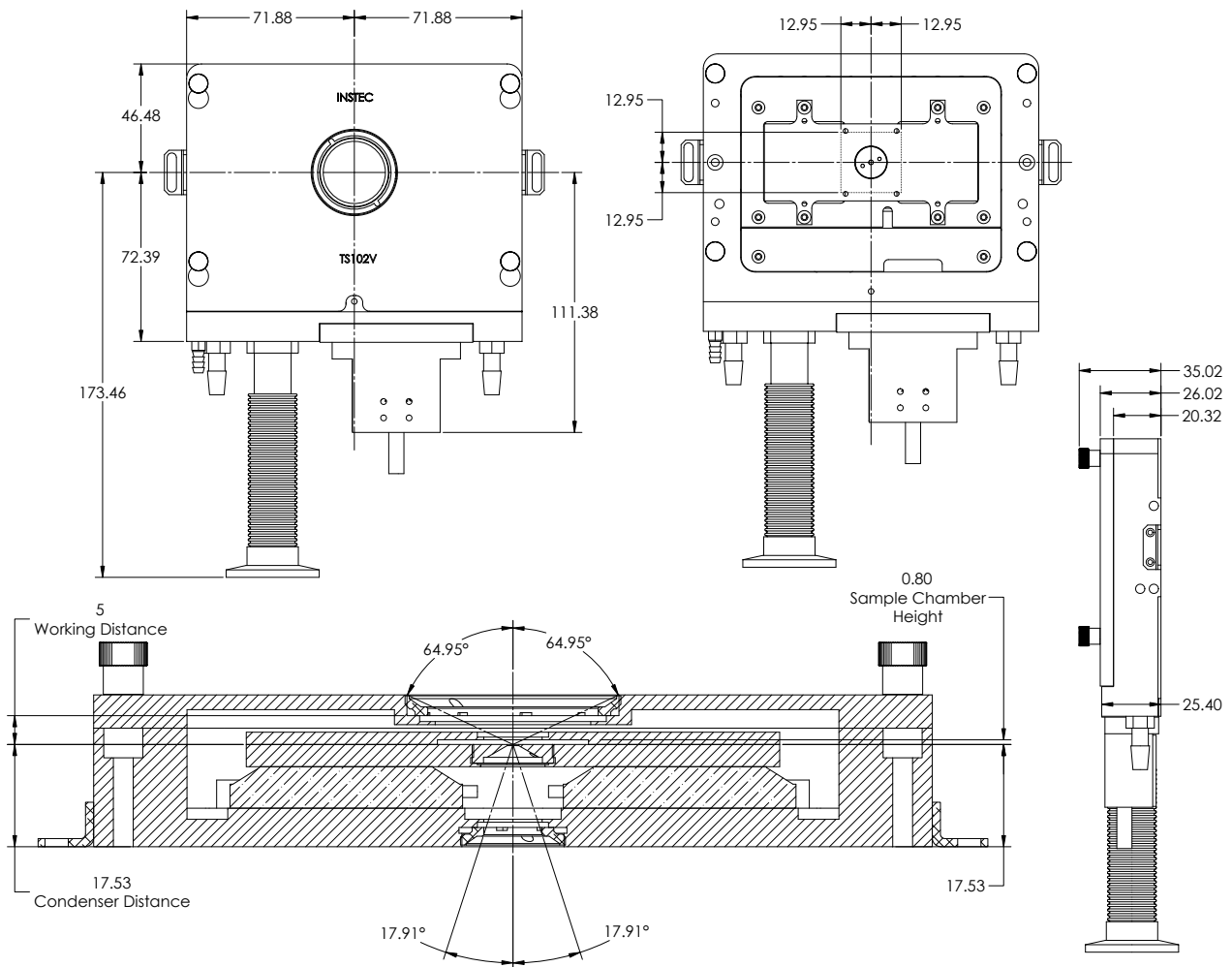

TS102V pictured. Contact Instec for information on other models.

TS104G

Thermal Large Area Gas-Tight Stage



Instec's TS104 stage is based on thermoelectric technology that provides a full range of heating and cooling (-30°C to 90°C) without requiring liquid nitrogen or a recirculating chiller. The TS104's robust design simplifies system set up, reduces operating costs, and makes it a convenient choice for performing long duration experiments with precision temperature control. This stage features an extra large 97 mm x 97 mm sample area, making it an ideal choice for inspecting LCD panels under a microscope.

The TS104 brings the convenience of thermoelectric heating and cooling to large format samples.



Features

- Programmable precision temperature from -30°C to 90°C
- Thermoelectric (Peltier) heating and cooling
- Accommodates up to a 97 mm x 97 mm sample size
- Controlled fast heating and cooling rate
- Large viewing aperture
- Removable and exchangeable windows
- Dual pane windows for better thermal isolation
- Integrated aperture window defrost system
- Gas-tight sample chamber
- Integrated Inner cover for improved sample temperature uniformity

Technical Specifications

Temperature Range	-30°C to 90°C
Temperature Resolution	0.01°C
Temperature Stability	±0.05°C at 37°C (better stability optional)
Minimum Heating and Cooling Rate	±0.1°C per hour
Maximum Heating Rate	+35°C per minute at 37°C
Maximum Cooling Rate	-15°C per minute at 37°C
Temperature Control Method	PID with Linear Variable DC
Temperature Control Sensor	100 Ω Platinum RTD
Minimum Objective Working Distance	7.6 mm
Minimum Condenser Working Distance	18.8 mm
Sample Area	97 mm x 97 mm
Chamber Height	2.9 mm
Sample Viewing Aperture	2 mm for transmitted light, 97.6 mm for reflected light
Weight	1,550 g

*5 or 8 mm aperture for transmitted light available by request.

Ordering Information

Part Number	Description
TS104G-mK2000	TS104G, thermal stage with mK2000, 115V/230V, software included
HT-A+120C	Optional higher temperature limit to 120°C, for TS102, TS104, TC102, TC104, TP102, TP104
F2-C-01	Two sealed electric feedthroughs, can only be ordered with hot and cold stage/plate

Please refer to Accessories section for mK2000 temperature controller options, cooling accessories, mounting adapters, and microscope accessories.

Physical Dimensions and Mechanical Drawings

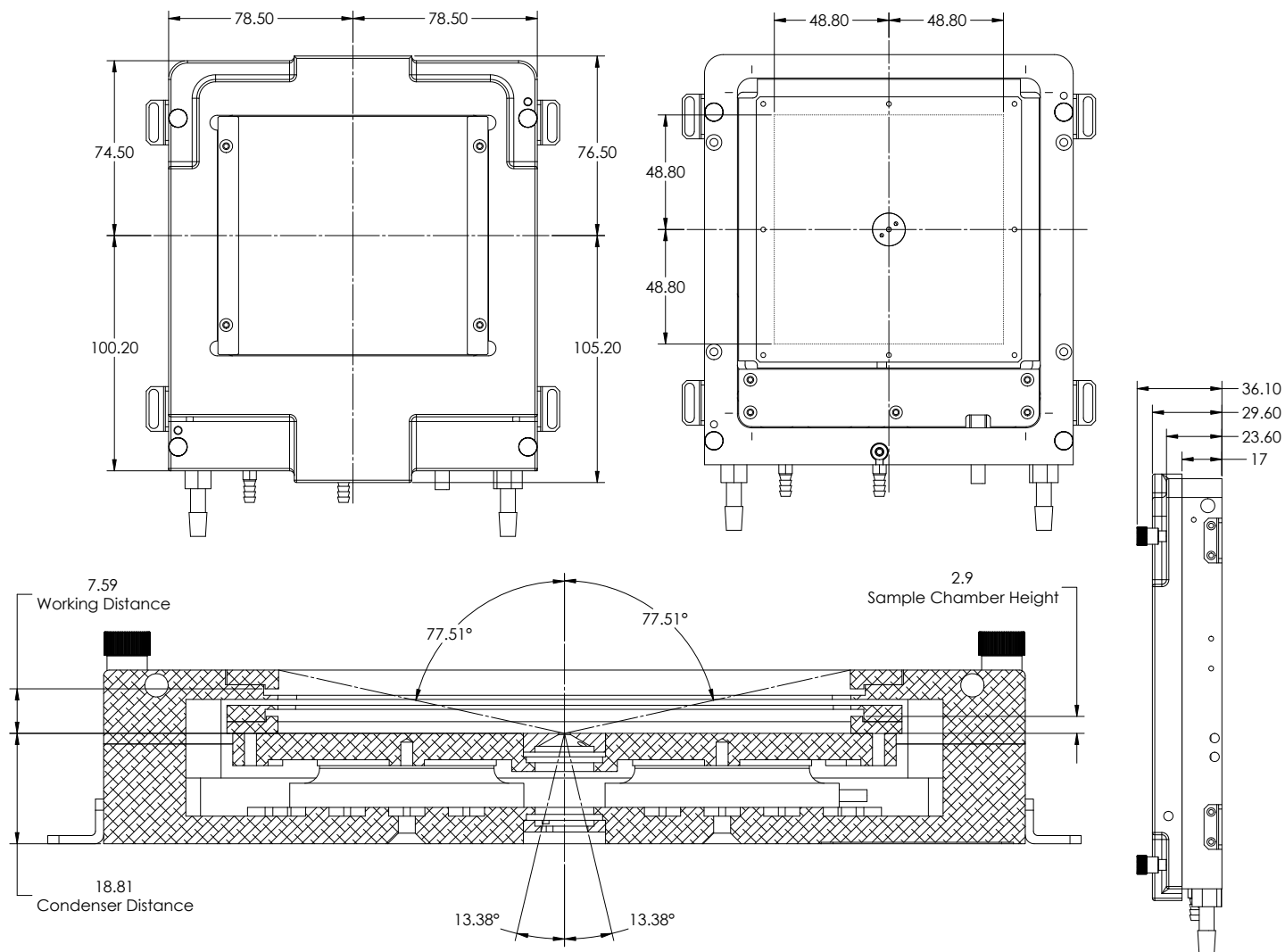

HCS321Gi

Hot & Cold Gas-Tight Inverted Stage



Instec's HCS321Gi hot and cold stage is designed specifically for inverted optical microscopes. Its small form factor allows for easy mounting onto all common inverted microscope platforms. The HCS321Gi offers the widest temperature range available for inverted microscope applications and a fully enclosed sample chamber for enhanced temperature uniformity.

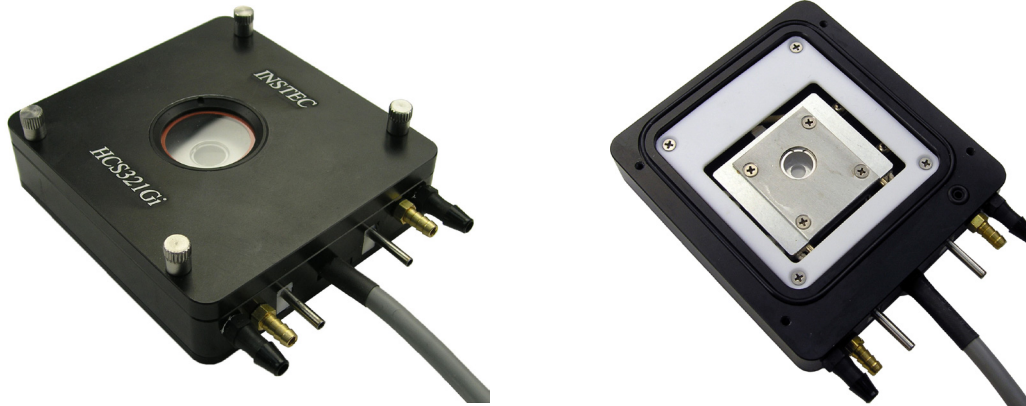

Features

- Programmable precision temperature from -80°C to 250°C
- Hot and cold stage system designed specifically for inverted microscopes
- Controlled fast heating and cooling rate
- Large viewing aperture
- Removable and exchangeable windows
- Dual pane windows for better thermal isolation
- Integrated aperture window defrost system
- Gas-tight sample chamber
- Inner cover for improved sample temperature uniformity
- Optional microscope stage mounting adapters available

Technical Specifications

Temperature Range	-80°C to 250°C Below ambient operation requires optional cooling accessory
Temperature Resolution	0.01°C
Temperature Stability	±0.05°C at 100°C (better stability optional)
Minimum Heating and Cooling Rate	±0.1°C per hour
Maximum Heating Rate	+120°C per minute at 100°C
Maximum Cooling Rate	-45°C per minute at 100°C
Temperature Control Method	Switching PID
Temperature Control Sensor	100 Ω Platinum RTD
Minimum Objective Working Distance	5.3 mm
Minimum Condenser Working Distance	11.9 mm
Sample Area	27 mm x 22 mm
Sample Chamber Height	10.4 mm
Sample Viewing Aperture	5 mm for transmitted light; 29.2 mm for reflected light
Stage Weight	610 g

*Sample area, chamber height and sample viewing aperture specifications given without inner cover in place.

Ordering Information

Part Number	Description
HCS321Gi-mK2000	HCS321Gi, inverted microscope hot and cold stage with mK2000, 115V/230V, software included

Please refer to Accessories section for mK2000 temperature controller options, cooling accessories, mounting adapters, and microscope accessories.

Physical Dimensions and Mechanical Drawings

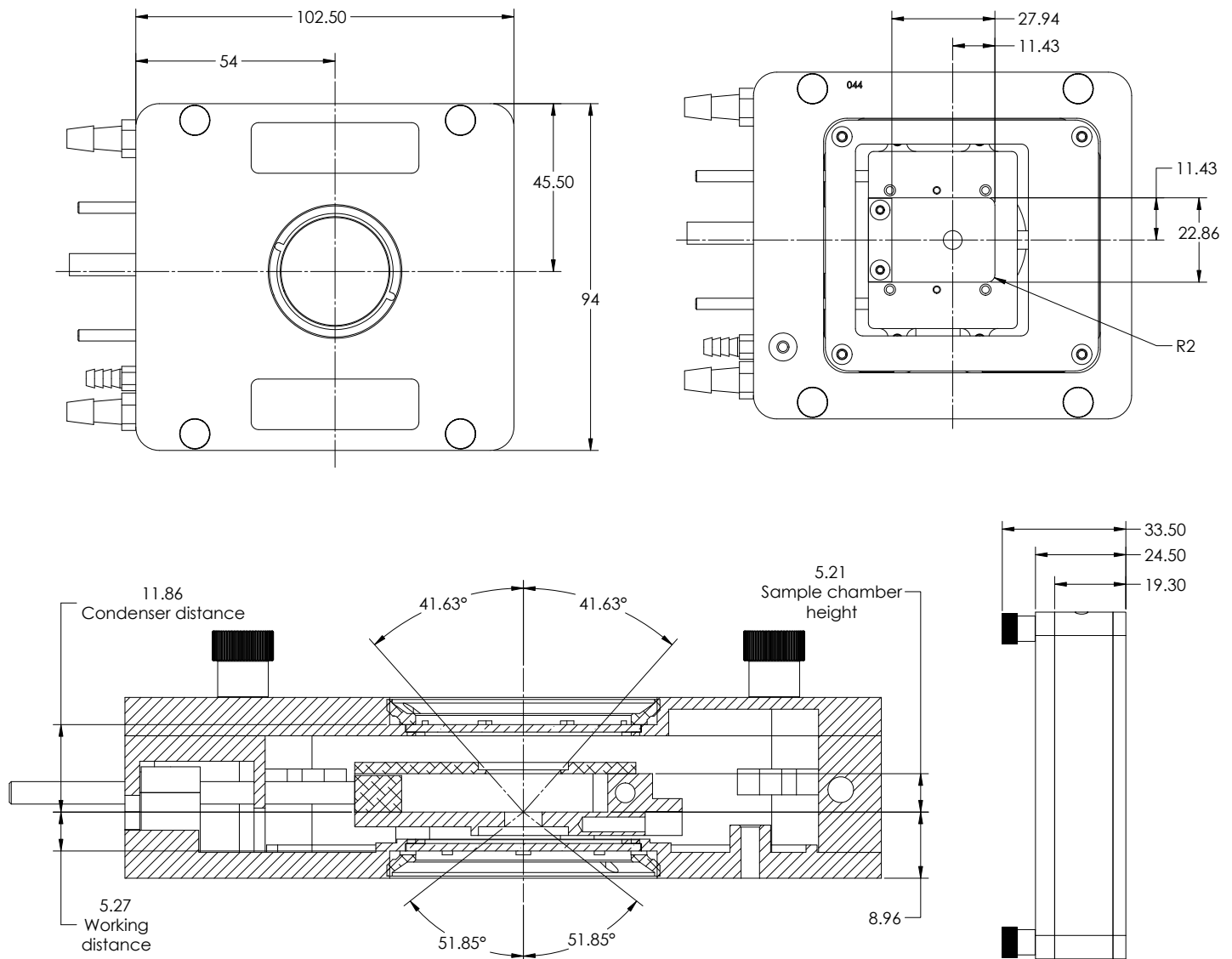

HS1300G / HS1400G / HS1500G

High Temperature Gas-Tight Hot Stages



Instec's HS1500 Hot Gas-Tight Stages can heat samples to 1500°C (depending on model) and are ideal for the study of ceramics, metallurgy, geology and high temperature materials. Electrical feedthroughs and custom sample areas are also available. Gas-tight sample chambers help to prevent sample oxidation at high temperatures.

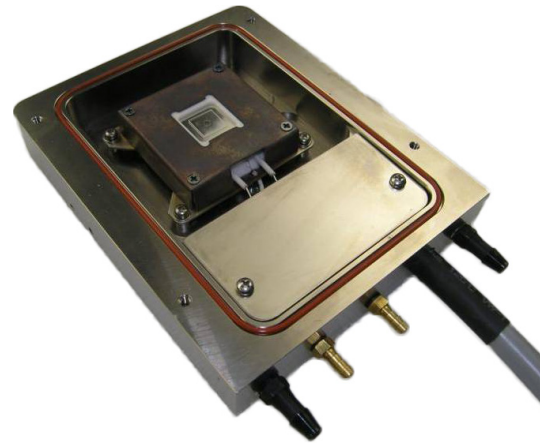

HS1500G pictured above

Features

- Programmable precision temperature from ambient to 1500°C (depending on model)
- Optional electric feedthroughs
- Controlled fast heating rate
- Removable and replaceable windows
- Gas-tight sample chamber
- Inner cover for maximum temperature uniformity
- Replaceable sapphire substrate to hold samples
- Vacuum wand for handling sapphire substrates
- Optional X-Y Micropositioner available for HS1300G and HS1400G

Technical Specifications

Temperature Range	HS1300G: Ambient to 1300°C HS1400G: Ambient to 1400°C HS1500G: Ambient to 1500°C
Temperature Resolution	0.1°C
Temperature Accuracy	±2°C below 600°C, ±3°C at 600~1500°C
Temperature Stability	±1°C below 600°C, ±2°C at 600~1500°C
Minimum Heating and Cooling Rate	±1°C per hour
Maximum Heating Rate	+300°C per minute at 100°C
Temperature Control Method	Switching PID
Temperature Control Sensor	S Type Thermocouple
Minimum Objective Working Distance	6.5 mm (HS1300G, HS1400G), 8 mm (HS1500G)
Minimum Condenser Working Distance	12 mm (HS1300G, HS1400G), 15 mm (HS1500G)
Sample Area	16 mm x 16 mm, 16 x 26 mm with XY
Chamber Height	1.4 mm with inner cover
Sample Viewing Aperture	1.7 mm for transmitted light, 38.5 mm for reflected light
Weight	1,420 g, 1,720 g with XY

Ordering Information

Part Number	Description
HS1300G-mK2000	HS1300 high temperature gas-tight hot stage with mK2000, 115V/230V, software included
HS1300GXY-mK2000	HS1300 high temperature gas-tight hot stage with mK2000, precision X-Y micropositioner, 115V/230V, software included
HS1400G-mK2000	HS1400 high temperature gas-tight hot stage with mK2000, 115V/230V, software included
HS1400GXY-mK2000	HS1400 high temperature gas-tight hot stage with mK2000, precision X-Y micropositioner, 115V/230V, software included
HS1500G-mK2000	HS1500 high temperature gas-tight hot stage with mK2000, 115V/230V, software included

Please refer to Accessories section for mK2000 temperature controller options, mounting adapters, and microscope accessories.

Physical Dimensions and Mechanical Drawings

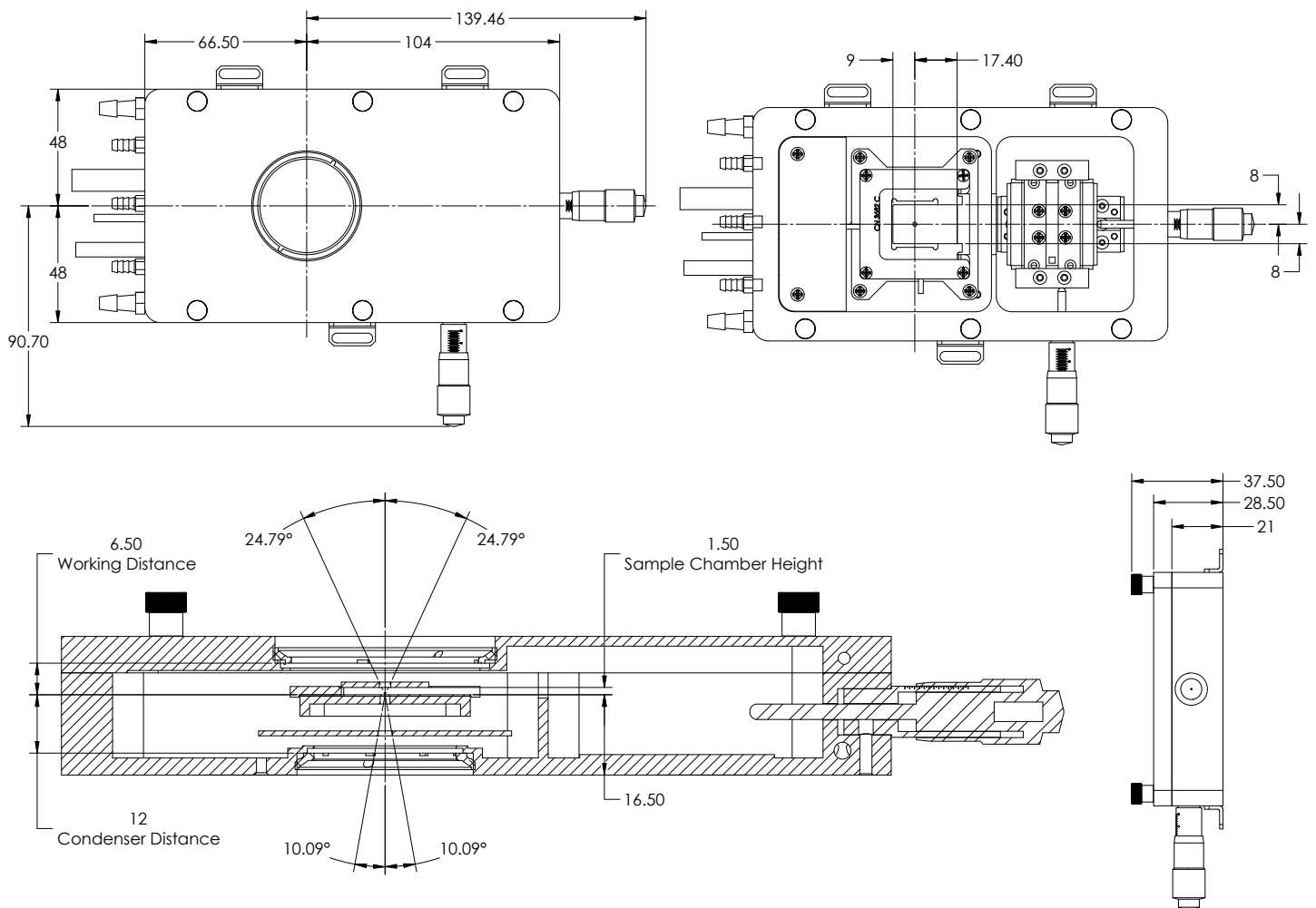

HS1400GXY pictured. Contact Instec for information on other models.

Instec's CLM77K is a specialized stage designed for use on any upright light microscope for correlative cryo-light and cryo-electron microscopy (CLEM). The specially designed grid holder allows up to nine 3 mm EM grids to be imaged via bright field and fluorescence light microscopy for determination of regions and/or cellular events of interest for later observation in the electron microscope. The grid holder is designed to keep the grids vitreous - well below the amorphous ice phase transition temperature - during transfer of grids into the grid holder and then into the CLM77K stage. To eliminate frost build up on samples, the chamber can be gas purged and the grid holder has an integrated slide cover that is closed during transfer from liquid nitrogen into the CLM77K chamber. The CLM77Ki is also available for inverted microscopes.

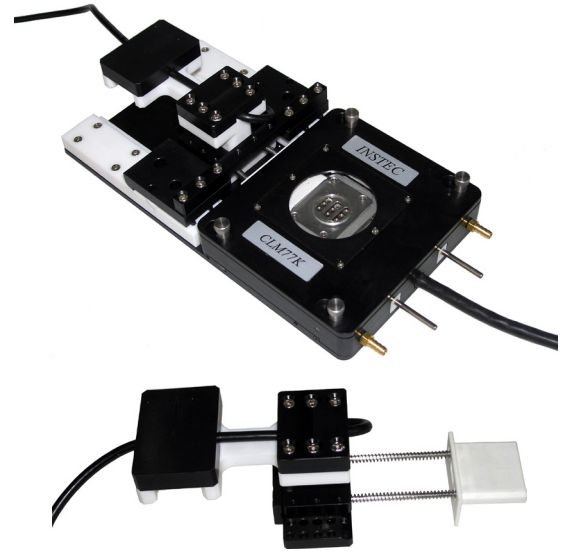

Features

- Programmable precision temperature from -190°C to 120°C
- Swing cover for easy sample access
- Specially designed cryo grid sample holder, capable of holding up to nine grids
- Grid holder remains chilled during transfers
- Integrated slide cover on grid holder to eliminate moisture condensation on samples
- Removable and exchangeable windows
- Dual pane windows for better thermal isolation
- Integrated aperture window defrost system
- Gas purge sample chamber
- Easy side sample loading with standard microscope slides
- Vertical and horizontal mounting
- Integrated precision X-Y micropositioner for in situ sample positioning
- Optional microscope stage mounting adapters available

Technical Specifications

Temperature Range	-190°C to 120°C LN2-SYS liquid nitrogen cooling system is included with the CLM77K
Temperature Resolution	0.01°C
Temperature Stability	±0.05°C at 100°C (better stability optional)
Minimum Heating and Cooling Rate	±0.1°C per hour
Maximum Heating Rate	+60°C per minute at 100°C (CLM77K); +80°C per minute at 100°C (CLM77Ki)
Maximum Cooling Rate	-50°C per minute at 100°C
Temperature Control Method	Switching PID
Temperature Control Sensor	100 Ω Platinum RTD
Minimum Objective Working Distance	5 mm
Minimum Condenser Working Distance	17.6 mm (CLM77K), 19.3mm (CLM77Ki)
Grid Holder	Holds nine 3 mm diameter sample grids
Sample Viewing Aperture	3 mm diameter
X-Y Micropositioner	10 μm resolution
Weight	1,280 g (CLM77K), 1,070 g (CLM77Ki)

Ordering Information

Part Number	Description
CLM77K-mK2000	CLM77K, hot and cold stage with mK2000, 115V/230V, software included
CLM77Ki-mK2000	CLM77Ki, hot and cold stage for inverted microscope with mK2000, 115V/230V, software included

Please refer to Accessories section for mK2000 temperature controller options, mounting adapters, and microscope accessories.

Physical Dimensions and Mechanical Drawings

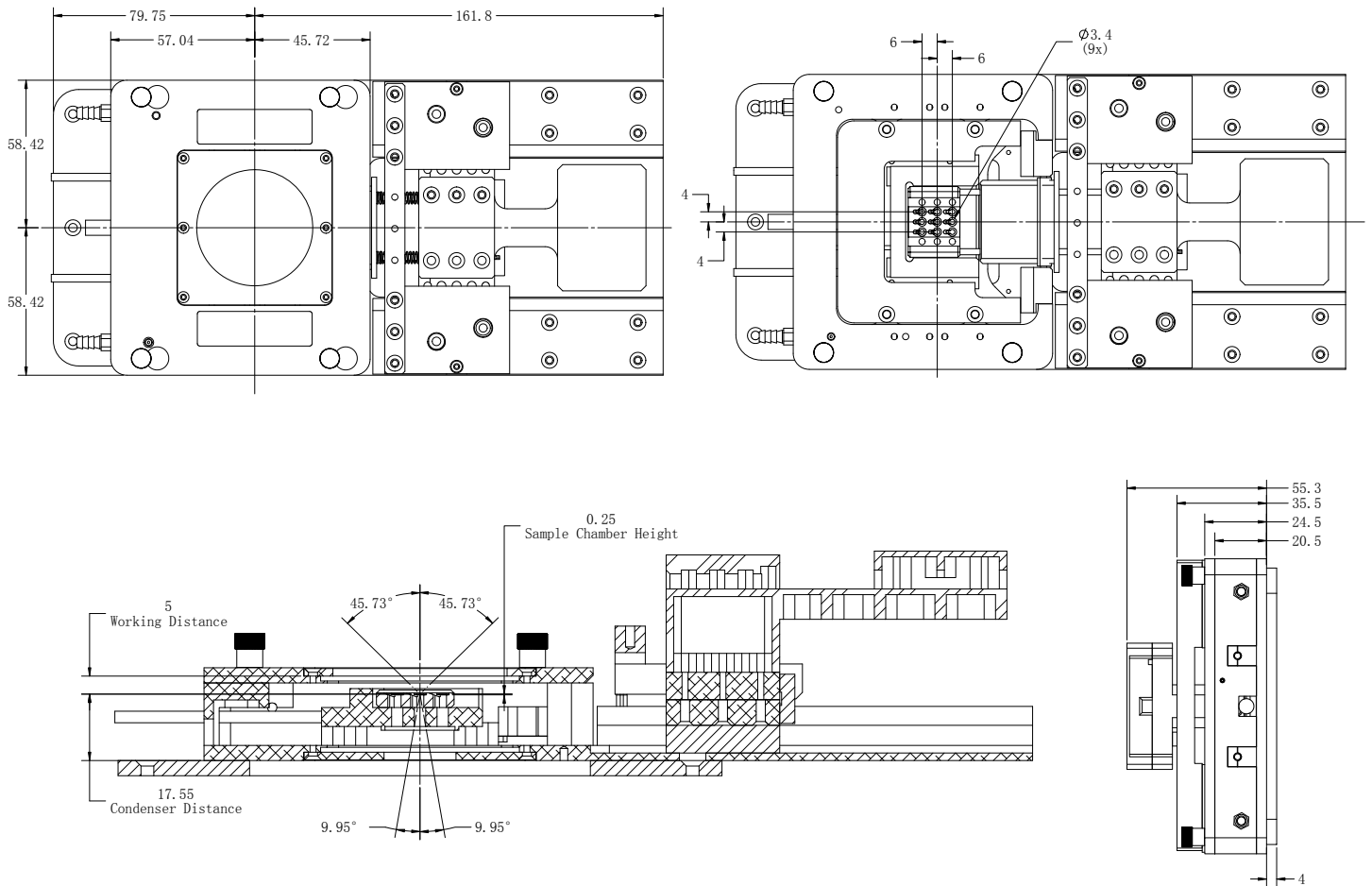

CLM77K pictured. Contact Instec for information on CLM77Ki.

FS1

Hot & Cold Thin Film Drawing Stage



Instec's FS1 stage is designed specifically for drawing a freely suspended thin film across the aperture for analysis by thermal microscopy. The PCB sample holder allows an electric field to be applied across the film. Freely suspended films that are only a few molecular layers thick are very sensitive to contamination. The FS1 is designed so that all of the internal components can be removed and cleaned easily between experiments, reducing the risk of contamination from previous samples. Applications for this stage include liquid crystals, polymers, colloids, other complex fluids and optical tweezers.

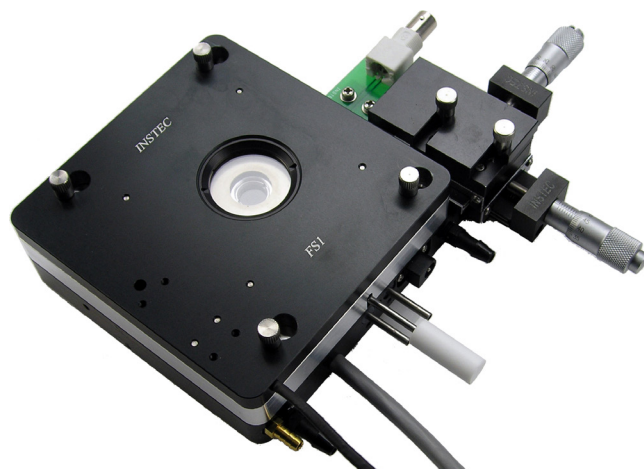

Features

- Programmable precision temperature from -60°C to 200°C
- Dual heaters located above and below the sample chamber for superior temperature uniformity
- Thin film drawing kit
- Angled viewing aperture to reduce reflections
- Removable inner chamber for easy cleaning
- Extra large viewing aperture
- Removable and exchangeable windows
- Dual pane windows for better thermal isolation
- Integrated aperture window defrost system
- Precision X-Y micropositioner for in situ sample positioning

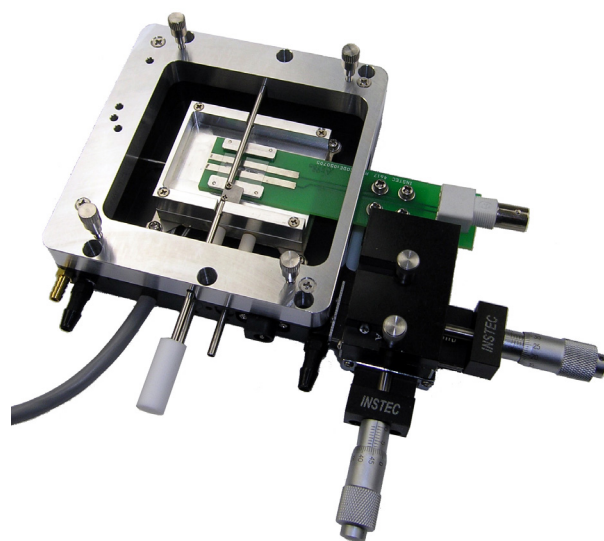

Technical Specifications

Temperature Range	-60°C to 200°C Below ambient operation requires optional cooling accessory
Temperature Resolution	0.01°C
Temperature Stability	±0.05°C at 100°C (better stability optional)
Minimum Heating and Cooling Rate	±0.1°C per hour
Maximum Heating Rate	+65°C per minute at 100°C
Maximum Cooling Rate	-15°C per minute at 100°C
Temperature Control Method	Switching PID
Temperature Control Sensor	100 Ω Platinum RTD
Minimum Objective Working Distance	19.7 mm
Minimum Condenser Working Distance	15.4 mm
Sample Area	38 mm x 58 mm
Sample Viewing Aperture	5 mm for transmitted light; 7.5 mm for reflected light
X-Y Micropositioner (optional)	10 μm resolution
Weight	1,350 g

Ordering Information

Part Number	Description
FS1-mK2000	FS1, hot and cold stage with mK2000, 115V/230V, software included

Please refer to Accessories section for mK2000 temperature controller options, cooling accessories, mounting adapters, and microscope accessories.

Physical Dimensions and Mechanical Drawings

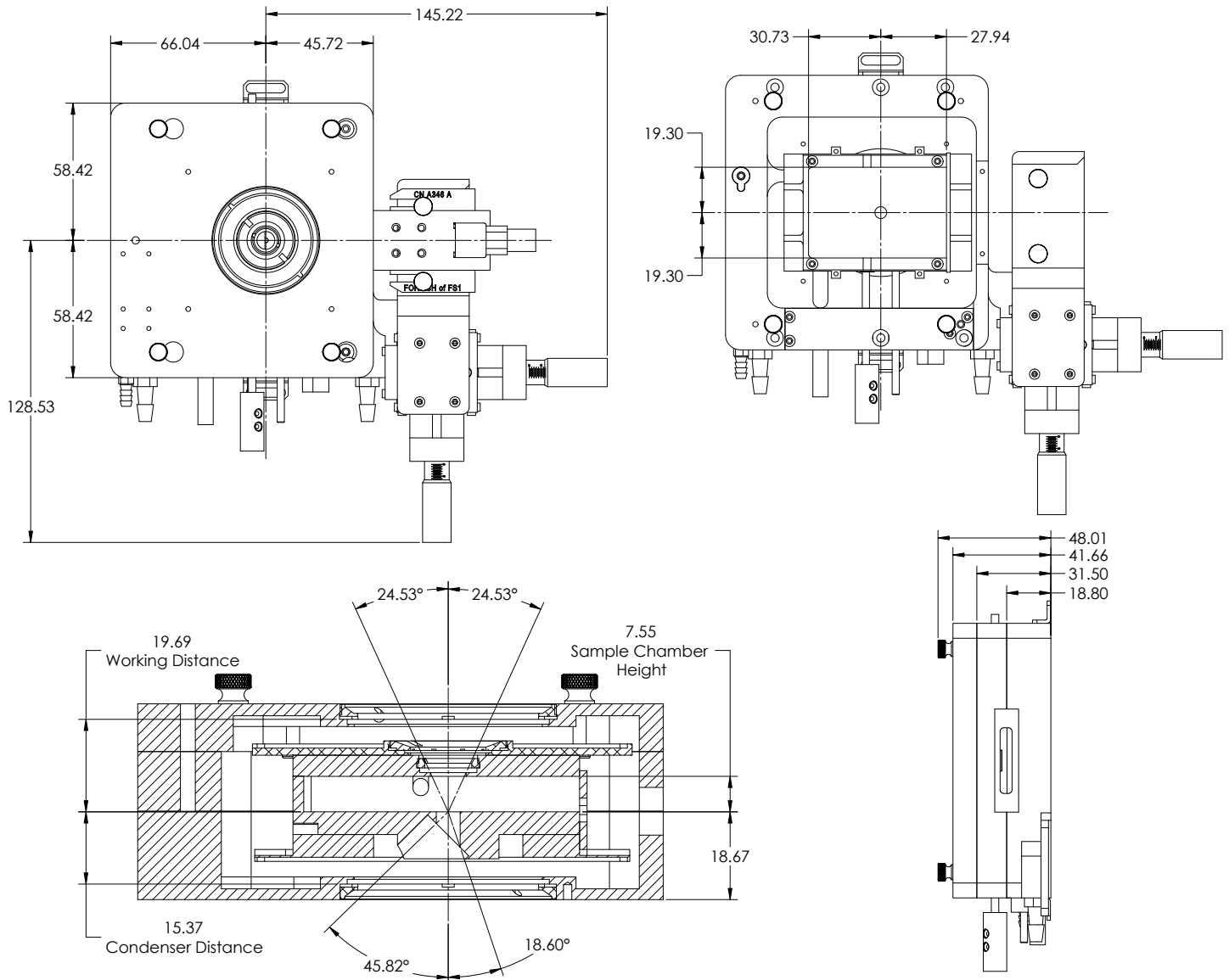

After selecting the proper hot and cold stage for your application, the following accessories are recommended to complete your system.

Sample Area Cooling

For Instec's hot and cold systems, a sample cooling accessory must be selected for below-ambient operation. Recirculating chillers (p. 36) provide rapid cooling of the sample area to below 5°C (depending on model). Liquid nitrogen systems (p. 34) will provide sample cooling to as low as -190°C.

X-Y Micropositioner & Sample Holder

X-Y micropositioners (p. 39) can be added to side-loading stage models for precise positioning of the sample within the viewing aperture. X-Y micropositioners can be used together with glass microscope slides and with Instec LC cell and sample holders (p. 40).

Mounting Adapters

Instec carries a variety of mounting adapters (p. 38), both for mounting samples within Instec stages, and for integrating Instec products with microscopes, spectrometers and other instrumentation.

Spacer Kits

Spacer kits (p. 39) are available extend the chamber heights of both the inner cover and outer lid. Spacers should be ordered when using RSH-S1 or LC cell holders.

Frame Cooling

Frame cooling supplied by a recirculating chiller (p. 36) will regulate the frame temperature of your Instec stage, keeping it safe to touch and preventing frost buildup.

Imaging Accessories

Instec's imaging and microscopy accessories are designed to help you get the most out of your Instec system. The LWDC2 long working distance condenser (p. 41) allows for correct Kohler illumination of samples inside Instec stages when doing transmitted light microscopy. The MITO2 microscope camera with temperature overlay (p. 42) seamlessly integrates with Instec's temperature control software to automate image capture and data recording.

Temperature Controller

Instec stages, plates and chucks come paired with an mk2000 high precision temperature controller. Optional mk2000 configurations are available (p. 44).



A complete Instec system, including:

1. mK2000 temperature controller
2. HCS302 with X-Y micropositioner, mounting ring and 3 mm spacer kit installed
3. LCH-S11 liquid crystal sample holder
4. LN2-SYS liquid nitrogen cooling system
5. MITO2 microscope camera with c-mount
6. ALCT-IV1 automatic liquid crystal testing system
7. LWDC2 long working distance condenser

Instec's LN2-SYS liquid nitrogen cooling systems provide fast and accurate cooling for Instec stages, chucks, and plates. Each system consists of a liquid nitrogen pump, a Dewar, and the necessary tubing. Dewar lids have a stoppered port so that LN2 can be refilled without stopping cooling. The pump generates suction, pulling liquid nitrogen from the Dewar and through the hot and cold stage, chuck, or plate. The pump is PID controlled by an Instec temperature controller with 0.1% resolution. This means when the stage, chuck, or plate is heating, the pump is off; when the pump is on, heating is off. The liquid nitrogen cooling systems are available with multiple pump options and either a 2, 10, or 30 liter Dewar.



Features

- Capable of cooling Hot and Cold Stages, Chucks, and Plates Down to -190°C
- System consists of an LN2-P pump, and an LN2-D Dewar
- 3 Pump sizes and 3 Dewar sizes available
- PID control provided when used with an Instec temperature controller



The temperature curves below were recorded using an Instec HCS302-mK2000 hot and cold stage system, LN2-P4UD2 liquid nitrogen cooling accessory, and C500W recirculating chiller.

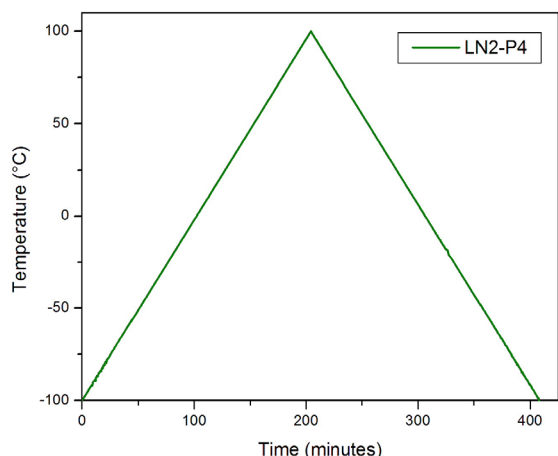

Temperature ramp of 1°C per minute using an LN2-P4 liquid nitrogen cooling system.

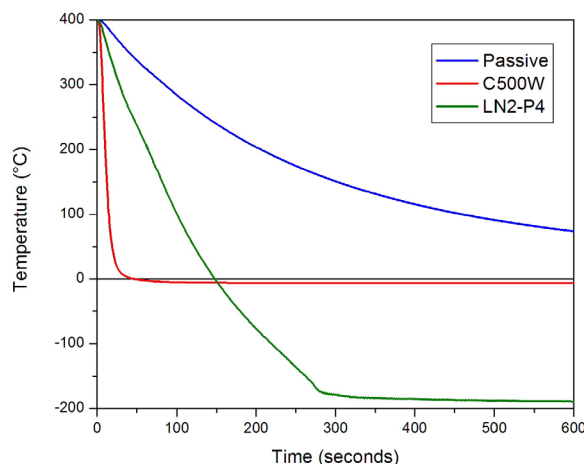

Maximum cooling rate for passive cooling, cooling using a C500W chiller, and cooling using an LN2-P4 liquid nitrogen cooling system.

Technical Specifications

Automatic Operation	PID controlled by Instec temperature controller
LN2-P Pump Dimensions	LN2-P: 261 mm x 355 mm x 156 mm
LN2-D Dewar Dimensions	LN2-D2: 258 mm diameter, 325 mm height LN2-D10: 322 mm diameter, 610 mm height

Model	Minimum Temperature		
	LN2-P2	LN2-P4	LN2-P8
HCS302	-100°C	-190°C	-190°C
HSC302G	-100°C	-190°C	-190°C
HCS402	-80°C	-190°C	-190°C
HCS412W	-60°C	-190°C	-190°C
HCS621G/V	-40°C	-190°C	-190°C
HCS622G/V	-80°C	-190°C	-190°C
HCS321Gi	-80°C	-80°C	-80°C
CLM77K/CLM77Ki	-	-190°C	-190°C
FS1	-	-60°C	-190°C

Ordering Information

Part Number	Description
LN2-P2AD2	Liquid nitrogen cooling system. Consists of an LN2-D2, two liter Dewar, and an LN2-P2, basic pump. 115V
LN2-P2UD2	Liquid nitrogen cooling system. Consists of an LN2-D2, two liter Dewar, and an LN2-P2, basic pump. 230V
LN2-P4AD2	Liquid nitrogen cooling system. Consists of an LN2-D2, two liter Dewar, and an LN2-P4, medium duty pump. 115V
LN2-P4UD2	Liquid nitrogen cooling system. Consists of an LN2-D2, two liter Dewar, and an LN2-P4, medium duty pump. 230V
LN2-P8AD10	Liquid nitrogen cooling system. Consists of an LN2-D10, ten liter Dewar, and an LN2-P8, high capacity pump. 115V
LN2-P8UD10	Liquid nitrogen cooling system. Consists of an LN2-D10, ten liter Dewar, and an LN2-P8, high capacity pump. 230V
LN2-P8AD30	Liquid nitrogen cooling system. Consists of an LN2-D30, thirty liter Dewar, and an LN2-P8, high capacity pump. 115V
LN2-P8UD30	Liquid nitrogen cooling system. Consists of an LN2-D30, thirty liter Dewar, and an LN2-P8, high capacity pump. 230V

CW Series Recirculating Chillers

The CW Series recirculating chillers are a convenient option for continuous sample and frame cooling of Instec Stages. Frame cooling makes Instec stages safe to handle while heating and prevents frosting when working at low temperatures. Frame cooling also extends the temperature range of Peltier-based (thermoelectric) stages. Chillers can also provide rapid cooling of the Hot and Cold stage sample area to below 5°C (depending on model).

C300W, **C500W** and **C610W** chillers can be used on their own for frame cooling of hot and cold Stages. Coolant flow control systems are available to allow chillers to provide sample cooling for Hot and Cold Stages and frame cooling for Peltier stages (see below).

C300W-R and **C500W-R** chillers includes a communication port for controlling frame cooling to Peltier based stages.



Coolant Flow Control Systems

Coolant flow control systems can be paired with the C300W, C500W and C610W chillers to provide extended capabilities for those systems.

FVC1 allows any chiller to be used for frame cooling of a Peltier stage.

FVC9 allows any chiller to be used for simultaneous sample and frame cooling of a hot and cold Stage.



Chiller	Weight	Dimensions	Temperature range (no load)	Hot & Cold Stage Frame cooling	Hot & Cold Stage Sample cooling	Peltier Stage Frame Cooling
C300W	14.5 kg	37 x 27 x 47 cm	Ambient to 50°C	Yes	With FVC9	With FVC1
C500W	37 kg	46 x 28 x 56 cm	1°C to 50°C	Yes	With FVC9	With FVC1
C610W	65 kg	89 x 48 x 71 cm	1°C to 50°C	Yes	With FVC9	With FVC1
C300W-R	14.5 kg	37 x 27 x 47 cm	Ambient to 50°C	Yes	Yes	Yes
C500W-R	37 kg	46 x 28 x 56 cm	1°C to 50°C	Yes	Yes	Yes

Water Cooling of Samples

The temperature curves below were taken using an Instec HCS302-mK2000 hot and cold stage system, LN2-P4UD2 liquid nitrogen cooling accessory, and C500W recirculating chiller.

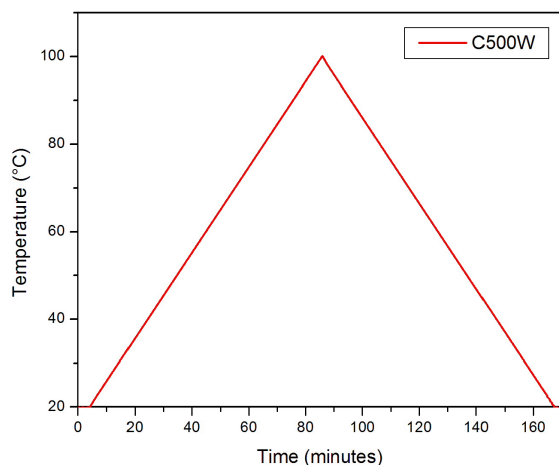

Temperature ramp of 1°C per minute using a C500W recirculating chiller

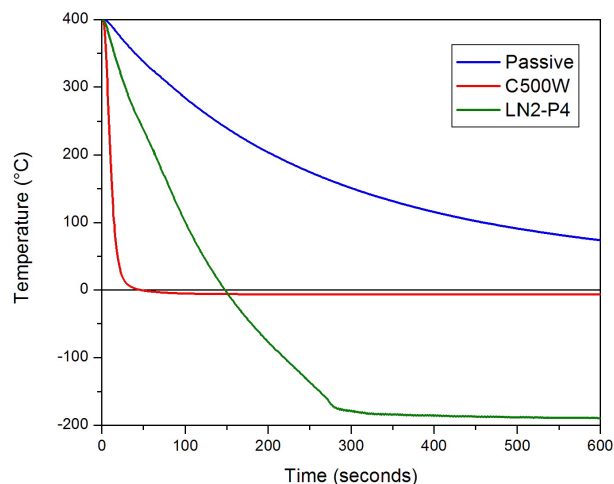

Maximum cooling rate for passive cooling, cooling using a C500W chiller, and cooling using an LN2-P4 liquid nitrogen cooling system.

Ordering Information

Part Number	Description
C300W	300 W recirculating chiller, 115V/230V
C500W	500 W recirculating chiller, 115V/230V
C610W	610 W recirculating chiller, 115V/230V
C300W-R	300 W recirculating chiller with communication port, 115V/230V
C500W-R	500 W recirculating chiller with communication port, 115V/230V
FVC1	Coolant flow control system for frame cooling of Instec Peltier Stages, 115V/230V, controlled by out3 of mK2000
FVC9	Coolant flow control system for frame and sample cooling of Instec Hot and Cold Stages, 115V/230V, controlled by out2 of mK2000

Vertical Mounting Adapter

Instec offers a vertical mount for applications where it is necessary to mount an Instec stage perpendicular to the benchtop. This is particularly useful for integrating an Instec stage into a spectroscopic instrument such as an FTIR or laser table.

The adapter shown measures 9.2 cm to the center of the aperture. Custom aperture heights and mounting point configurations are also available. Contact Instec for customized adapter ordering information.



Dovetail Mounting Adapter

Instec's dovetail mounting adapter allows an Instec stage to be mounted in place of a microscope's rotational stage. The adjustable thumb screws make this ring compatible with microscope dovetail sizes 11.4 cm and smaller.



Rotational Stage Mounting Rings

Rotational stage mounting rings allow an Instec stage to be mounted onto an existing microscope rotational stage. This style of mounting ring can be attached to the bottom of an Instec stage and seats inside the aperture of the rotational stage. Instec offers a selection of standard adapters for commonly used rotating stages. If your rotational stage aperture doesn't correspond to a diameter from the list below, contact Instec for information about custom adapter options.



Part Number	Microscope Model	Diameter
MT-OLY-01	Olympus Rotational Stage Model: U-SRG2	71.88 mm
MT-OLY-02	Olympus Rotational Stage Model: U-SRP	69.85 mm
MT-NIK-01	Nikon E300/E600 POL	25.8 mm
MT-ZEI-01	Zeiss Axioskop 40 POL	23.8 mm
MT-LEI-01	Leica DM EP	69.85 mm
MT-LEI-02	Leica DM 2500P Rotational Stage	29.8 mm
MT-MEI-01	Meiji M37-to-27.95	27.95 mm

Spacer Kits

InsteC offers spacers for most hot and cold stage and hot and cold plate models, which include an inner spacer, outer spacer, and inner skirt. The spacer allows for increasing the sample chamber height to accommodate a thick sample.

Spacers should be ordered together with liquid crystal cell holders and the RSH-S1 sample holder. Contact InsteC for spacer options.

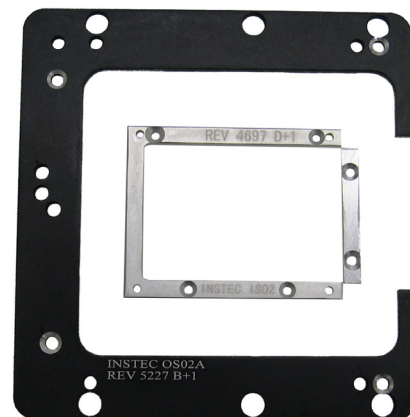

X-Y Sample Micropositioner

The transmitted light apertures of InsteC hot and cold stages are typically kept relatively small in order to maximize temperature uniformity of the sample. Because of this, it is better to move the sample inside the hot and cold stage rather than the hot stage itself. InsteC offers optional X-Y Micropositioners to extend the capability of any stage model that offers side sample loading. Micropositioners feature micrometer heads with 10 μm resolution and ± 5 mm of travel from the center position. A mounting adapter for InsteC LC cell holders and glass microscope slides is included.

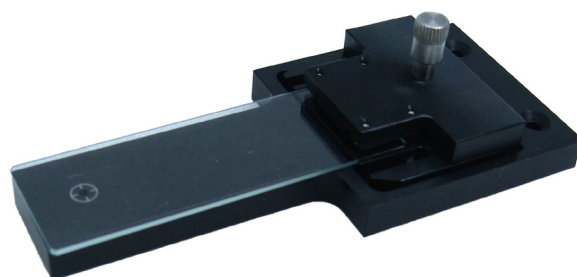
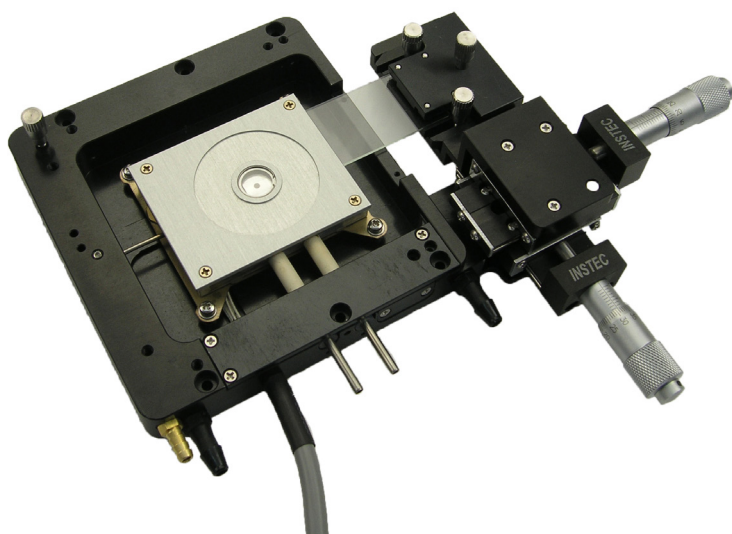
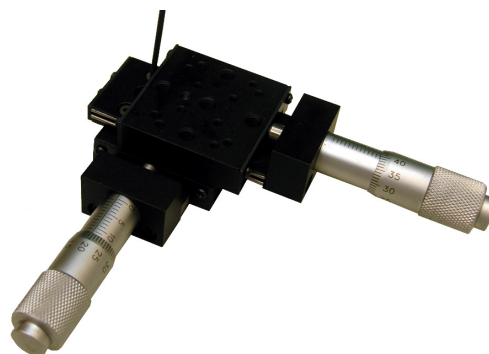

InsteC's side loading stages come standard with a microscope slide holder, which can be used together with the X-Y Micropositioner. The side holder kit includes a tray marked with a guide for positioning the sample area to be in line with the stage's aperture.

Liquid Crystal Cell Holders

The LCH-S11 is designed to apply electrical field to Instec's S-type and IPS liquid crystal cells using two BNC connectors. The flip style lid securely contacts the LC cell for use over a wide temperature range. This cell holder can be used with any side-loading Instec stage, with or without a micropositioner and is fully compatible with Instec's ALCT liquid crystal testing instruments. A hot and cold stage spacer kit must be installed when using this product.

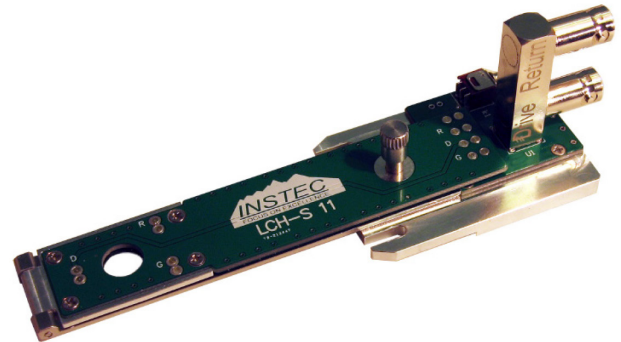

The LCH-S9 is designed to be a flexible option for applying an electric field to liquid crystal cells of various sizes and shapes using two BNC connectors. Conductive tape is provided for making electrical contact between the holder and the LC cell up to temperatures of 85°C. This cell holder can be used with any side-loading Instec stage, with or without a micropositioner and is fully compatible with Instec's ALCT liquid crystal testing instruments. A hot and cold stage spacer kit must be installed when using this product.

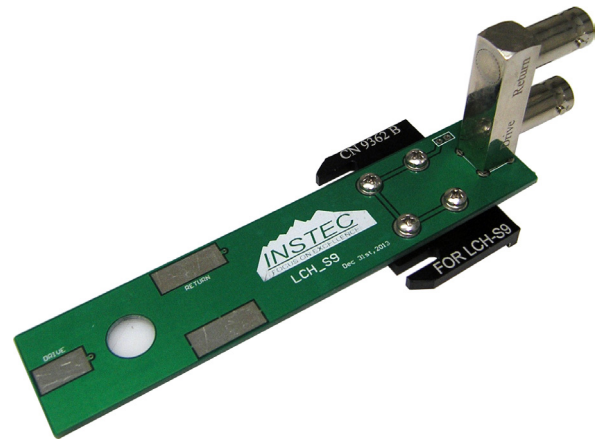

General Sample Holder

The the RSH-S1 sample holder (shown on the right) spectroscopic windows securely in place, allowing them to be used with a vertically mounted stage. This is a useful option for IR spectroscopy. The RSH-S1 can be used with any side-loading Instec stage, with or without a micropositioner and holds 12.5 mm windows. A hot and cold stage spacer kit must be installed when using this product.

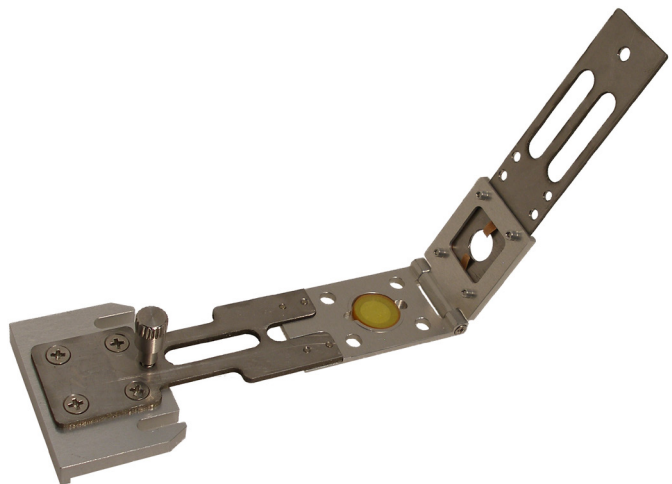

Modern microscopes generally use Kohler Illumination, which separates the image of the light source from that of the sample, increasing the uniformity of the light at the sample position and allowing the condenser's aperture to be used to control the numerical aperture. If the condenser's position is not correctly adjusted, the intensity of the light reaching the sample is reduced, the uniformity decreased, and worst of all stray light can show up as glare. Therefore to get the best performance from a high quality microscope, it is important that the condenser working distance be large enough to reach the sample.

The Instec Long Working Distance Condenser (LWDC2) provides a longer working distance than a conventional condenser, compensating for the increased space between the sample and condenser when using an Instec hot and cold stage. The LWDC2 condenser provides the proper Koehler illumination and the best possible sample image.



Features

- 20 mm working distance
- Detachable and rotatable polarizer
- Universal dovetail fitting compatible with most upright optical microscopes
- Adjustable condenser aperture iris
- Ideal for thermal microscopy applications

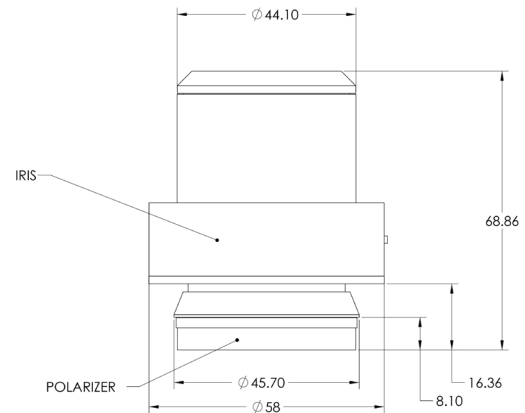

Technical Specifications

Working Distance	20 mm
Mounting	Universal dovetail, compatible with most major upright microscope brands, such as Olympus, Nikon, Zeiss, Leica, & Meiji. Please contact Instec if your microscope is from a different manufacturer.
Numerical Aperture	0.55

Ordering Information

Part Number	Description
LWDC2	Long working distance condenser with rotatable and detachable polarizer

MITO2

Microscope Camera With Temperature Overlay



Instec's MITO2 camera system integrates digital image acquisition and time-temperature recording into a convenient package for use with Instec's microscope hot and cold stages and plates. USB communication and passive cooling make the MITO2 camera a fast and robust option for adding digital image acquisition to any optical microscope. Using our WinDV software, each sample image is stamped with the sample temperature, time and date, and experiment notes provided by the user. Captured images are also software indexed to allow for easy sorting and movie creation. WinDV's features include temperature-triggered image capture (convenient for generating clean and precise temperature-property data), live video feed for positioning samples, easy snap capture for single images, and all of the temperature control features normally found in our WinTemp software.



Features

- USB 2.0 communication
- Real time image monitoring and image capture
- Temperature-triggered image capture for easy collection of temperature-property data
- C-mount microscope connection standard
- 1.92 megapixel UXGA resolution
- WinDV software overlays sample temperature, time & date, and other experiment notes directly onto the digital images when interfaced with an Instec temperature controller

2015-03-12 12:10:52
118.329°C
Banana-shaped liquid crystal

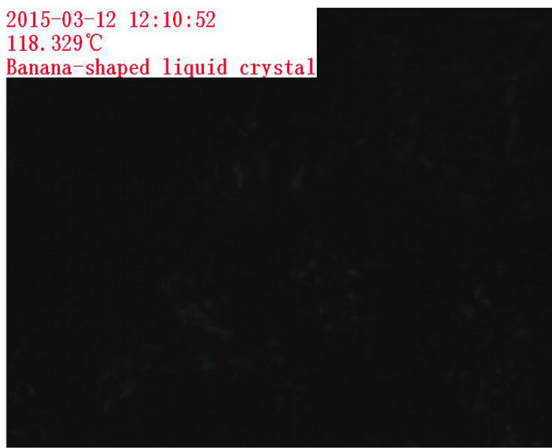

2015-03-12 12:12:48
118.520°C
Banana-shaped liquid crystal

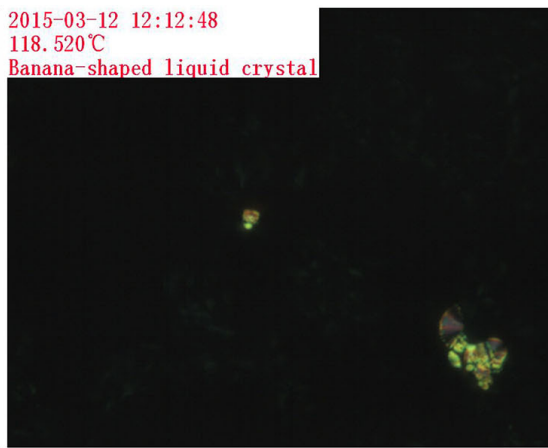

2015-03-12 12:17:03
118.930°C
Banana-shaped liquid crystal

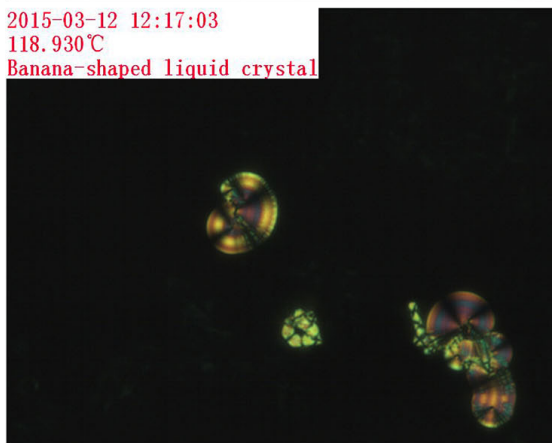

2015-03-12 12:26:32
119.874°C
Banana-shaped liquid crystal

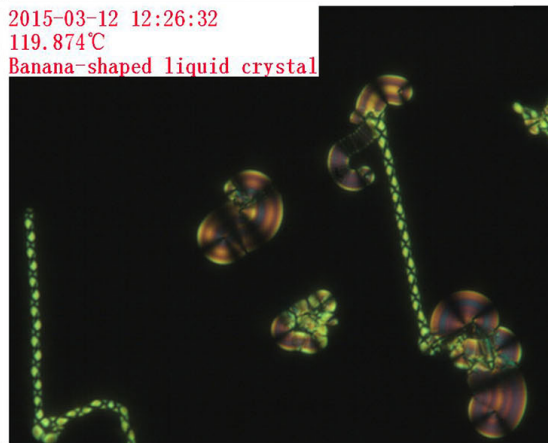

Images are automatically stamped with time, temperature and experimental notes for easy reference. Let the MITO2 do the record keeping for you!

Technical Specifications

Image Sensor	1/1.8" Interline UXGA color progressive CCD: ICX274AQ (Sony)
Chip Size	8.50 (H) x 6.80 (V) mm
Resolution	1600 (H) x 1200 (V) (1.92 megapixel)
Scanning System	Progressive
Scanning Methods	Full scanning, 1/1 partial scanning, 1/2 partial scanning, 1/4 partial scanning, variable partial scanning
Maximum Frame Rate (Full Scanning)	15.32 fps
Pixel Frequency	36.818 MHz
Video Output	8bit / 10bit (1/2 clock) / 12bit (1/4 clock)
Minimum Scene Illumination	7.7 Lux at F1.2
Sync System	Internal
Electronic Shutter	Auto / Manual (software selectable)
Gain	Auto / Manual (software selectable)
Gamma	Manual (software selectable)
White Balance	Auto / Manual
Trigger Mode	Free-run / Edge preset trigger / Pulse width trigger / Start & stop trigger (software selectable)
Input / Output	USB 2.0 High Speed
Input Voltage	+5 Vdc through USB connector (+4.4 to +5.25 V)
Power Consumption	< 450 mA
Dimensions	28 (W) x 28 (H) x 42 (D) mm (excluding connector)
Lens Mount	C mount
Weight	Approximately 45g
Interface Connector	USB: mini-B USB connector IO signal: 6 p in connector (HR10A-7R-6PB or equivalent)
Operational Temperature	0 to 40°C
Storage Temperature	-30 to 65°C
Vibration	20 Hz to 200 Hz to 20 Hz (5 min. /cycle), acceleration 10G, 3 directions 30 min. each
Shock	Acceleration 70G, half amplitude 6 ms, 3 directions 3 times each
Standard Compliancy	EMS: En61000-6-2, EMI: EN61000-6-3 (Class B)
RoHS	RoHS Compliant

Ordering Information

Part Number	Description
MITO2-2MC	C-mount ready microscope CCD camera system with 1.92 megapixel resolution, RGB-color image.
CMT	C-mount Adaptor for Olympus BX microscope.

mK2000

Temperature Controller



The mK2000 is an easy-to-use system for precision temperature control of any Instec hot and cold stage, plate or chuck. The mK2000 features a maximum temperature resolution of 0.001°C and can be configured for use with either platinum RTDs, thermocouples or thermistors. The front panel interface allows easy standalone programming and control, while the standard USB2.0 communication port and included WinTemp software provides computer control and data recording. The mK2000 can store up to five temperature profiles for routine experiments. For those wishing to communicate with the mK2000 using Labview, a sample VI is available upon request. Optional RS232, Ethernet and IEEE488 communication ports are also available. The mK2000 is an ideal choice for demanding temperature control applications.



Features

- Suggested for use with all Instec hot and cold stages, plates and chucks
- 24 bit analog to digital converter
- Dual PID outputs for precise heating and cooling
- Includes WinTemp software for simple computer control and data handling
- USB2.0 communication port (RS232, Ethernet and IEEE488 ports also available)
- Easy to use as a standalone controller
- Optional LVDC heating for low EMI applications
- Up to 20 calibration points
- Built in power-off protection against overheating
- CE certified
- Stores up to five temperature profiles (WinTemp software allows additional profiles to be saved to a PC)
- Integrates with Instec ALCT products as a complete system for temperature-property measurements

Technical Specifications

Control Algorithm	Switching PID
Maximum Temperature Resolution	0.001°C with thermistor, 0.01°C with RTD, 0.1°C with thermocouple
Controlled Heating Rate	System dependent
Controlled Cooling Rate	Please contact your Instec representative for more information
Host Interface	USB 2.0 (RS232, Ethernet and IEEE488 options available)
Host Software	WinTemp included (Labview VI upon request)
Dimensions	346 mm x 257 mm x 156 mm

mK2000 Options

mK2000 Options	Description
IEEE-mK2000	IEEE488 (GPIB) communication port for the mK2000
RS232-mK2000	RS232 communication port for the mK2000
IP-mK2000	Ethernet port for the mK2000
LVDC-mK2000	Linear variable DC power supply for the mK2000

WinTemp Software

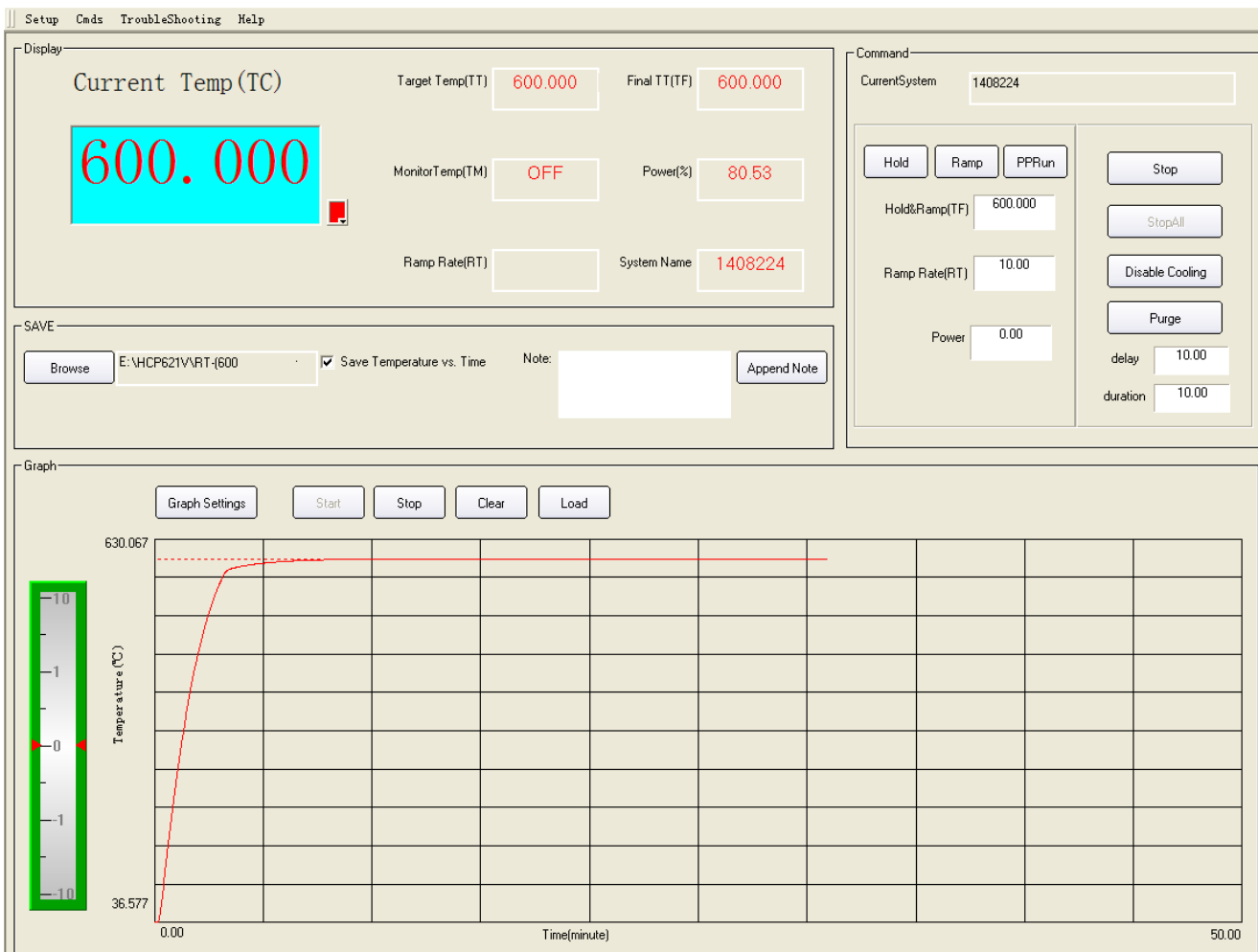

Instec's WinTemp software provides a simple PC interface for the mK2000 allowing users to easily send commands, create temperature profiles and collect data. In addition to streamlining access to the features available using the mK2000 front panel, WinTemp displays a real-time graphical view of the system set-point and current temperature. Data collected using WinTemp can be conveniently saved and reviewed at a later time or opened using a spreadsheet application.

Aperture

An opening through which light is admitted.

Condenser Working Distance

The distance between the sample and the exit lens of the condenser.

Chuck

As used in this catalog, a chuck refers to a heating and cooling system with a series of vacuum grooves and holes on the surface which can be used to hold down the sample.

C-Mount

A standard lens mount often used for connecting cameras to microscopes.

Dual Heater

A dual heater is an Instec design which uses two heaters, one above the sample, and the other below the sample. This design allows for the near elimination of vertical thermal gradients across the sample. It may also be employed to produce a well regulated thermal gradient, or a constant thermal gradient across the sample.

Gas Defrost

The use of a dry gas to clear or prevent the condensation of moisture on viewing windows during low temperature operation.

Gas Purge

A sample chamber with an inlet for introducing a flow of gas into the chamber.

Gas-Tight

An enclosed sample chamber.

IEEE-488 (GPIB)

The Institute of Electrical and Electronics Engineers or IEEE is one of the leading standards maintaining organizations in the world. Used in this catalog to indicate when a communication port adheres to the IEEE-488 communication standard.

ITO (Indium Tin Oxide)

Indium tin oxide (ITO, or tin-doped indium oxide), a mixture of indium(III) oxide (In_2O_3) and tin(IV) oxide (SnO_2), is an electrically conductive material. It is transparent in thin layers.

Liquid Crystal Cell

Typically a structure composed of two flat pieces of glass with a small (usually on the order of a few to several tens of microns) gap which can be filled with liquid crystal. The inner surfaces of the glass pieces are normally coated with ITO allowing an electrical potential difference to be applied and may also be coated with an alignment layer (e.g. a rubbed polyimide) which aligns the liquid crystal molecules at the surfaces. In this catalog, LC cells refer to unfilled or empty LC cells.

NPT - National Pipe Thread

National Pipe Thread is a U.S. standard for tapered (NPT) or straight (NPS) threads used to join pipes and fittings.

Objective Working Distance

The distance between the front surface of the objective and the in focus specimen.

Peltier/Thermoelectric Cooler

Thermoelectric cooling uses the Peltier effect to create a heat flux between the junction of two different types of materials. A Peltier cooler, heater, or thermoelectric heat pump is a solid-state active heat pump which transfers heat from one side of the device to the other side against a temperature gradient (from cold to hot), with consumption of electrical energy.

PID - Proportional-Integral-Derivative

A proportional-integral-derivative controller (PID controller) is a generic control loop feedback mechanism widely used in industrial control systems.

Plate

As used in this catalog, a plate refers to a heating and cooling system with a flat sample area which does not include a viewing aperture or vacuum holes and grooves.

RTD - Resistance Temperature Detector

Resistance thermometer, also called resistance temperature detector (RTD), is a temperature sensor that exploits the predictable change in electrical resistance of some materials with changing temperature.

RS232

In telecommunications, RS-232 (Recommended Standard 232) is a standard for serial binary data signals connecting between a DTE (Data terminal equipment) and a DCE (Data Circuit-terminating Equipment). It is commonly used in computer serial ports.

Stage

As used in this catalog, a stage refers to a heating and cooling system which includes a sample chamber with a viewing aperture to allow light or other beams to pass through.

Temperature Accuracy

Accuracy is the degree to which a temperature measurement of a system agrees with the true temperature of the system.

Temperature Gradient

The temperature gradient, or thermal gradient is a measure of how the temperature of an object, a system, or a volume of space changes with respect to position.

Temperature Stability

Stability, as used in this catalog or in reference to Instec products, refers to the repeatability of a measured temperature value of a system with respect to time. For instance a stable temperature indicates that the temperature of a system is constant, or unchanging with respect to time.

Temperature Precision

Precision, also called reproducibility or repeatability, is the degree to which multiple temperature measurements of a system show the same or similar results.

Temperature Resolution

Resolution is the minimum temperature difference that can be measured or controlled by a system.

Temperature Uniformity

Uniformity, as used in this catalog or in reference to Instec products, refers to a small or zero change in a measured temperature value of a system with respect to position in that system. For instance, a highly uniform temperature would indicate that the measured temperature of a system is the same regardless of the position in the system where the measurement was taken.

Thermocouple

In electronics, thermocouples are a widely used type of temperature sensor and can also be used as a means to convert thermal potential difference into electric potential difference.

Vacuum Compatible

Vacuum compatible, as used in this catalog or in reference to Instec products, refers to the ability of a system, such as a hot and cold stage to minimally impact (with normal use) the vacuum of a chamber when introduced into the chamber.

Vacuum-Tight

Vacuum-tight refers to the ability of a sample stage to maintain a vacuum.

How To Contact Us

For Customer Service/Technical Support contact us at:

Phone: +1-303-444-4608

Fax: +1-303-444-4607

E-mail: support@instec.com

Web Site: www.instec.com

How To Order

By telephone during business hours

+1-303-444-4608

Monday - Friday 8 AM to 5 PM, Mountain Time

By fax or e-mail 24 hours a day

Fax: +1 303-444-4607

E-mail: sales@instec.com

By mail on your official purchase order

Instec, Inc.

5589 Arapahoe Avenue #208

Boulder, CO 80303

USA

All orders are subject to Instec's terms and conditions, depending upon quantity, price, availability of parts and other considerations.

Minimum Billing

The minimum billing amount is \$300 for domestic and international orders.

Price

Prices are quoted F.O.B. Boulder, Colorado, USA and do not include sales or other taxes. Applicable taxes and freight charges will be shown as separate items on the invoice.

Prices are in US Dollars and are subject to change without notice.

All quotations are valid for 30 days unless otherwise stated.

Delivery

F.O.B. Boulder, Colorado, USA. All risks of loss shall pass to the buyer upon delivery at the F.O.B. point.

Instec shall select the means of transportation unless the buyer provides specific instructions with the order.

Payment Terms

Domestic Orders: Terms of payment are 30 days after shipment, subject to approved credit. New accounts must furnish necessary credit references. Until credit has been established, advance payment or C.O.D. may be requested. Visa, MasterCard, and American Express are accepted.

International Orders: All Prices are in USD. Advance payment via Telegraphic Transfer (T/T) or Letter of Credit is required (Instec will charge an additional fee for processing Letter of Credit). All international Quotations/Pro Forma Invoices DO NOT INCLUDE duties and taxes for the respective country of import.



Design and Specifications

Due to improvements in design and/or performance, some items may differ from catalog description and photography. Technical specifications and product dimensions may change without notice.

Cancellation and Return Policy

Orders for standard products may be canceled prior to shipment without charge. Shipped orders cannot be canceled or returned.

Special orders which require customization and/or modification cannot be canceled or returned once the order is placed.

Repair Inquires

Before returning any products for repair, please contact the Customer Service Department to obtain a "Return Materials Authorization (RMA) Number". To avoid processing delays, the RMA number should then appear on the outside of the returned package. The minimum repair charge is \$300.

Limited Warranty

Instec, Inc. warrants to buyer that the products will conform to the specifications set forth in its manual and will remain free of defects in workmanship and materials for a period of one year from the date of delivery. Should a product, malfunction during the warranty period because of a defect in workmanship or material, Instec will repair or replace it at no charge to buyer, provided the product has not been subject to accident, misuse, abuse, or unauthorized alteration, modification, and/or repair.

Examples of actions that will make this warranty null and void include, but are not limited to, the following:

- Storing or operating the device at any temperature outside the operating and storage temperature range.
- Performing or attempting to perform unauthorized service or repair.
- Resale — except through an authorized dealer.

Products requiring service under this WARRANTY should be delivered to Instec, Inc. All portions of such systems, hardware and software, should be returned, along with proof of purchase if obtained from a dealer. Buyer must insure the product or assume risk of damage or loss in transit. If unable to repair or replace the product, Instec will refund the purchase price paid by the original buyer.

DISCLAIMER

THE FOREGOING WARRANTY IS IN LIEU OF AND TO THE EXCLUSION OF ALL OTHER WARRANTIES, EXPRESS OR IMPLIED, INCLUDING WITHOUT LIMITATION, THE IMPLIED WARRANTIES OF MERCHANTABILITY AND FITNESS FOR A PARTICULAR PURPOSE. INSTEC, INC.'S LIABILITY AND THE BUYER'S EXCLUSIVE REMEDY FOR BREACH OF THE FOREGOING WARRANTY SHALL BE LIMITED TO THE REPAIR OR REPLACEMENT OF THE PRODUCT OR REFUND OF THE PURCHASE PRICE. UNDER NO CIRCUMSTANCES WILL INSTEC BE LIABLE TO THE BUYER IN ANY WAY FOR DAMAGES, INCLUDING ANY LOST PROFITS, LOST SAVINGS OR OTHER INCIDENTAL OR CONSEQUENTIAL DAMAGES ARISING OUT OF THE USE OR MISUSE OF THE PRODUCT, OR INSTEC'S BREACH OF THE FOREGOING WARRANTY.

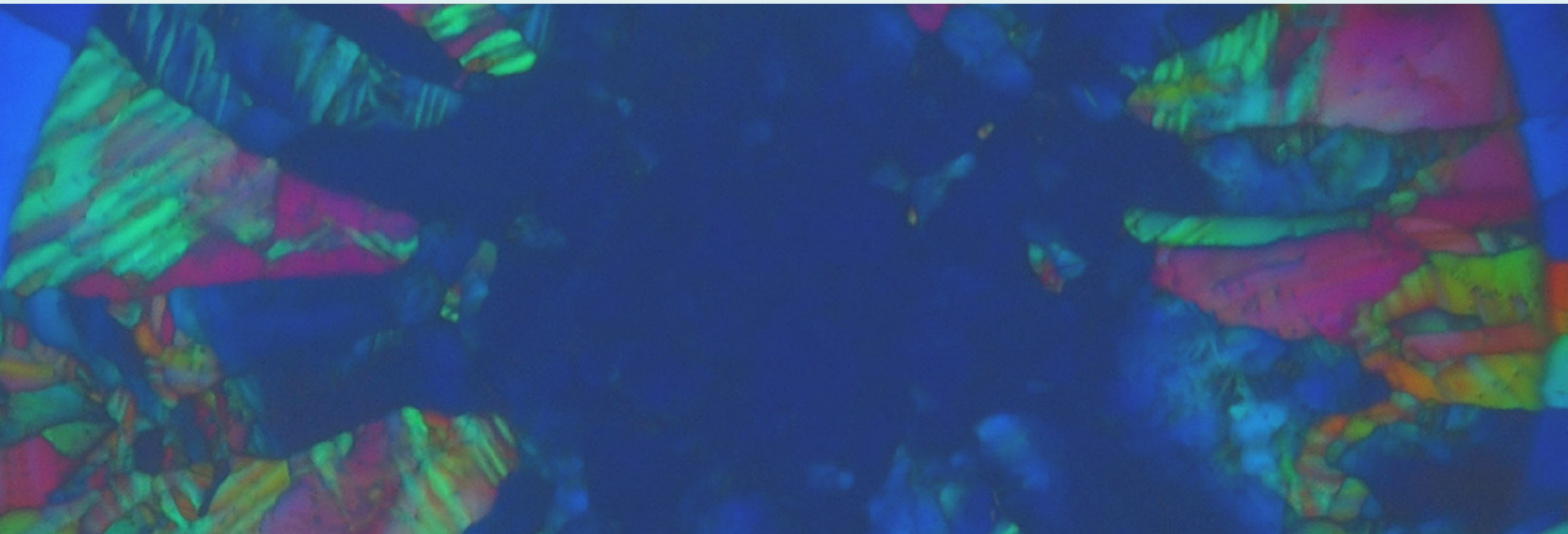

Instec, Inc.
5589 Arapahoe Avenue #208
Boulder, CO 80303
USA

Phone: +1-303-444-4608
Fax: +1-303-444-4607
Email: sales@instec.com

Represented by:

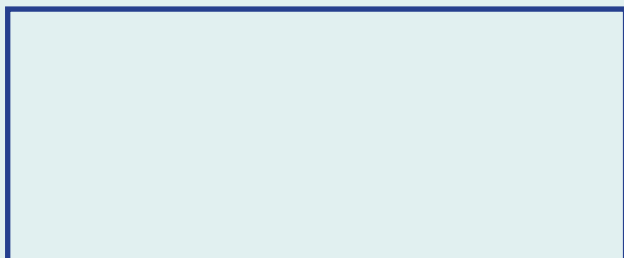

Liquid crystal image shown on cover is of a blue phase liquid crystal material. Courtesy of Professor Hui-Yu Chen, Feng Chia University, Taiwan